

GB



SISTEM-AIR

CENTRAL VACUUM SYSTEMS

MANUALE TECNICO

SISTEM Cube

1.	General information	
1.1.	The user guide	2
1.2.	Communications to the manufacturer	2
1.3.	Identification plate	2
1.4.	Technical Support	2
1.5.	Safety and security precautions	3
2.	Handling and unpacking	
2.1.	Handling and transport	3
2.2.	Unpacking	4
2.3.	Control of accessories	5
3.	Description of the Central Vacuum Unit	
3.1.	Operating principles and application field	6
3.2.	Allowed and improper use	6
3.3.	Basic Components	7
3.4.	Technical features	8
3.5.	Control panel description	8
4.	Installation	
4.1.	Precautions	8
4.2.	Area of installation	8
4.3.	Installation spaces	8
4.4.	Installation applications	9
4.5.	Installation template	9
4.6.	Installation on walls	9
4.7.	Installation on wooden or plaster walls	9
4.8.	Electrical connection	10
4.9.	Fixing the central vacuum unit to the installation template	11
4.10.	Removing the central vacuum unit from the installation template	11
5.	Use of the central vacuum unit	
5.1.	Starting of the central vacuum unit	12
5.2.	Use of the central vacuum unit	12
6.	Maintenance	
6.1.	Programmed maintenance	13
6.2.	Replacement of the dust container	13
6.3.	Replacement of the filter cartridge	15
6.4.	Cleaning of the filter cartridge	16
7.	Servicing	
7.1.	Servicing criteria	16
8.	Spare parts	
8.1.	Spare parts list	17
9.	Dismantling	
9.1.	General provisions	17
10.	Trouble shooting	
10.1.	Trouble shooting	18

1 - GENERAL INFORMATIONS

• 1.1 Utilising the user guide

The user guide is a fundamental document written by the builder, to be considered an integral part of the central suction unit.

We recommend storing and keeping the user guide throughout the whole operating life of the suction unit. The main purpose of the user guide is to provide a correct knowledge of the user mode in order to exploit the best performance and to maintain the central suction unit at its best working and security conditions. It is absolutely forbidden to duplicate copy or release totally or part of this user guide without previous written authorization by TECNOPLUS Srl, owner of the trademark SISTEM-AIR.

The manufacturer reserves the right to improve or modify the user guide and the machine itself at any moment, without prior notice.

• 1.2 Communications to the manufacturer

For any communication or request of assistance, we strongly suggest to always providing the following details, so to correctly identify the central vacuum unit model:

- Central vacuum unit model
- Item code
- Serial number
- Year of manufacturing
- Purchase date
- Purchase place
- Detailed information on the arisen troubles or on the kind of information required

All the technical data related to the central vacuum unit are indicated on the IDENTIFICATION PLATE situated on the central vacuum unit.

• 1.3 Identification plate

The identification plate is located inside of the unit on the front side. It contains the manufacturer name, the model, serial number, year of construction, the electrical tension supply (V), the frequency (Hz), the electrical absorption (A), the installed power (W)..

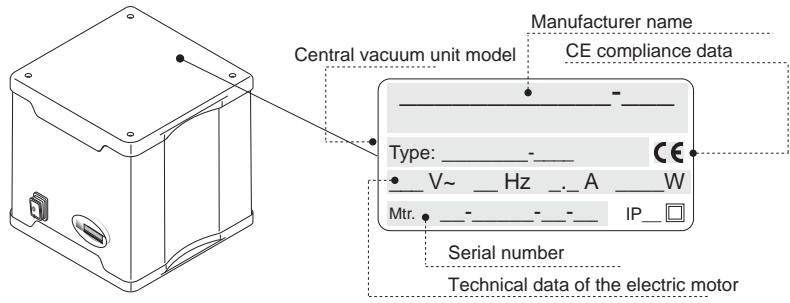

• 1.4 Technical Support

In case of need, exclusively call the Manufacturer Technical Service or an authorized centre always specifying the technical data indicated on the identification plate and the serial number of the central vacuum unit

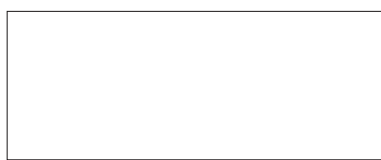

Manufacturer Assistance Service

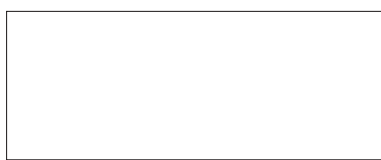

Authorized Assistance Centre

• 1.5 Safety and security precautions

Read carefully any information written in this user guide regarding installation, use and maintenance of the central vacuum unit.

Never use inappropriately the central vacuum unit.

Never let the children get near the central vacuum unit when it is working and never let the children play with the suction inlets or with the vacuum unit.

Unplug the central vacuum unit when:

- The power supply cable is worn out or damaged
- The central vacuum unit has been exposed to the inclemency of the weather or to excessive moisture.
- The central vacuum unit has been damaged by an impact or the external container has been damaged
- The central vacuum unit requires any repairing or overhauling.

Always wear protection gloves and mask when carrying out any maintenance operation and when unloading the dust container or replacing/cleaning the filter.

Use only original spare parts.

Never use the vacuum unit to remove textile stuff, big-size bits and pieces of any material, burning coals or ashes.

Never vacuum liquids.

Never block the air exhaust pipes and the cooling inlets of the motor.

Never touch the suction accessories with any part of the body.

Use only one inlet at a time.

Do not let the central vacuum unit running if you are not utilising it and put the switch on the "OFF" position if you are not going to use it for a long period.

et mettre l'interrupteur en position "OFF" en cas d'une longue période d'arrêt.

NEVER use the central unit without the dust bag cover.

NEVER take the central unit out from its template except for repairing carried out by qualified staff.

2 - HANDLING AND UNPACKING



- ATTENTION -
THE FOLLOWING OPERATIONS MUST BE CARRIED OUT
BY QUALIFIED STAFF
ALWAYS WEAR PROTECTIVE SHOES
AND GLOVES



2.1 Handling and transport

GROSS WEIGHT: kg 10

PACKING DIMENSION: cm 80 x 38.5 x H 31.5

CENTRAL UNIT WEIGHT: kg 4

Place the central unit still packed near the location of installation.

The small dimensions and the light weight do not require any special handling system. If necessary, use a trolley or ask for somebody's help.

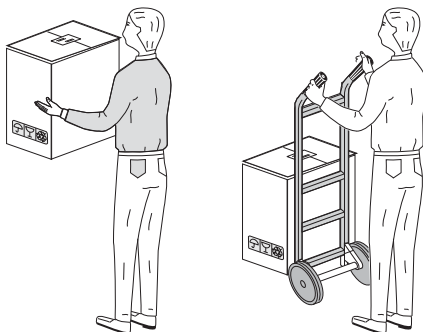

• 2.2 Unpacking

It is suggested not to unpack the central unit until you put it into service, in order to keep the central unit in perfect conditions.

ATTENTION:

The packing materials delivered with the central unit are inert solid wastes that must be disposed as per the regulations in force.

To unpack proceed as follows

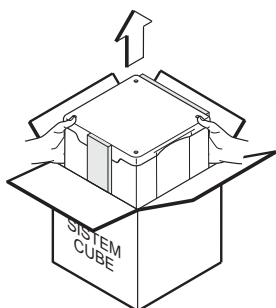
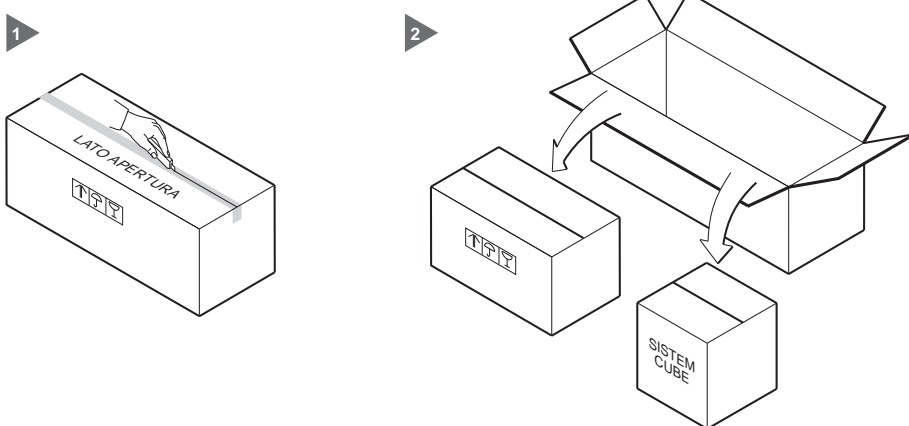



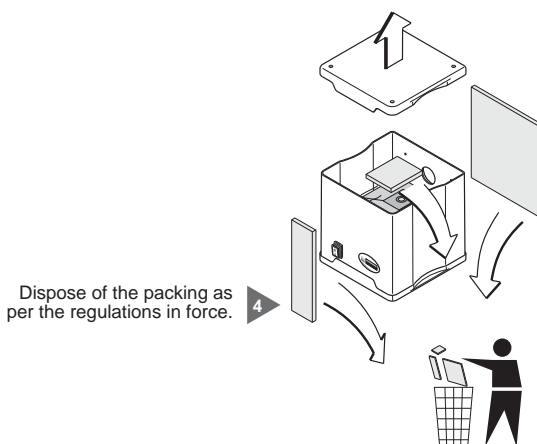





3 Open the top and take out the packing material and the accessories placed inside the central unit.

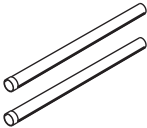

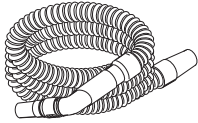
Dispose of the packing as per the regulations in force.

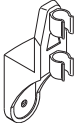
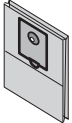
5 Take out all the accessories inside the accessories box.

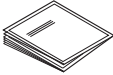
• 2.3 Check of the accessories

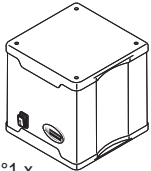
N°1 x 	N°1 x 	N°1 x 	N°1 x 
N°1 x 	N°1 x 	N°10 x 	N°1 x 
N°1 x 	N°1 x 	N°1 x 	

3 - DESCRIPTION OF THE CENTRAL VACUUM UNIT

• 3.1 Operating principles

The central suction system, suitable for any kind of residential building (house, office, hotels, service building) consists of a PVC pipes network, under the floors, inside the walls or the false ceiling, spreading in the various rooms and with the suction inlets placed at the end of each sector.

The central vacuum unit, located in utility rooms, garages or similar places, is connected to the piping network. The user starts the central vacuum unit by simply inserting the fitting of the suction hose into the suction pipe inlet.

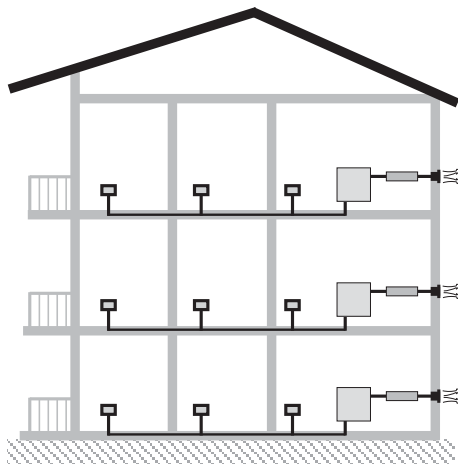

• 3.2 Allowed and improper use.

The central vacuum unit has been designed to remove the dust, small-size solid bits and pieces and dry materials. It is forbidden to use the vacuum system to remove textile stuff, big-size bits and pieces, burning and hot materials.

NEVER vacuum liquids!

Do not vacuum organic material that may ferment.

It is strictly forbidden to remove highly explosive materials (gun powder) or inert materials, which can trigger dangerous chemical reactions if removed separately and then mixed up in the dust container.

It is strictly forbidden to use the central suction unit in explosion hazard places or in places where temperature, pressure and moisture are out-of-range.

Any different use is strictly forbidden.

The manufacturer must approve, by means of written authorization, any alteration or modification of the suction unit to remove a specific material. Any use different from the original is to be considered improper and health risk for the user and damage to the suction unit cannot be excluded.



• 3.3 Basic components

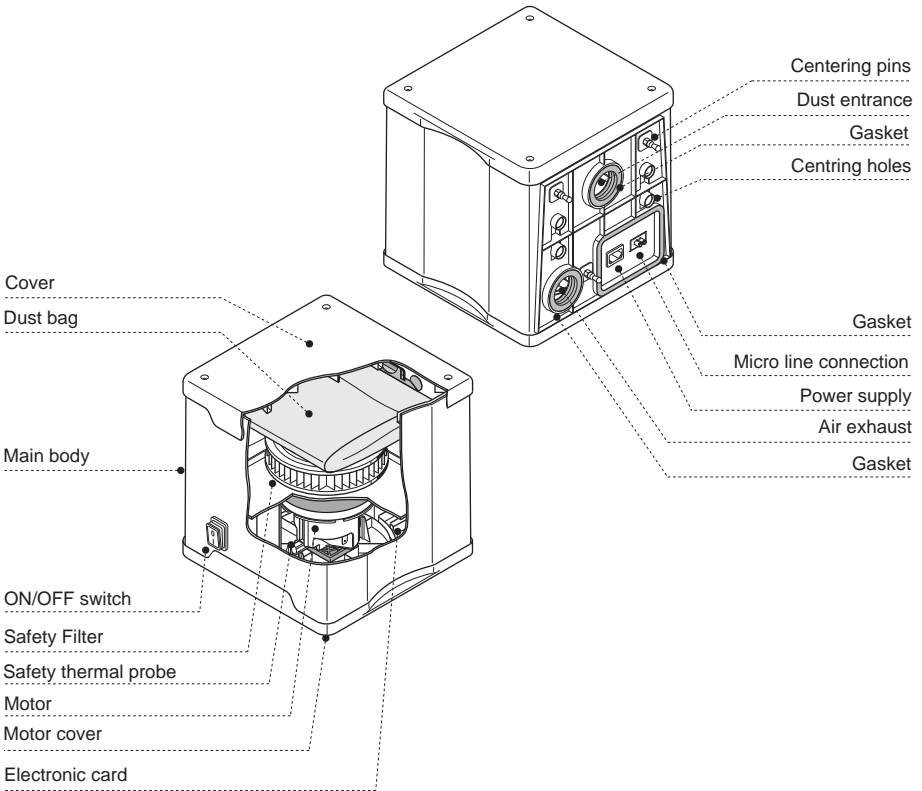
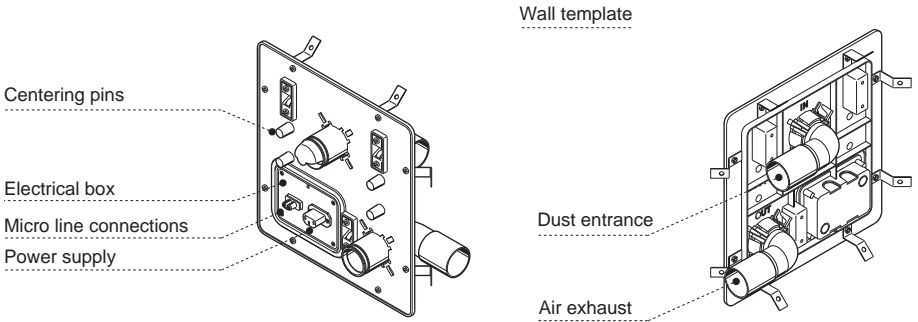

• 3.4 Technical features

Technical features		
N° users Max		1
Surface max	m ²	150
Pipes	Ø mm	40
Power supply	Volt ac	220/240
Frequency	Hz	50/60
Motor power	kW	1
Absorption	A	4.5
Inlet power supply	Volt dc	12
Max air volume	m ³ /h	178
Dust container capacity	litri	5
Safety filter		YES
Weight	kg	4

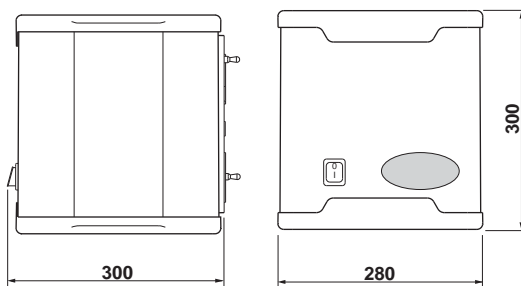
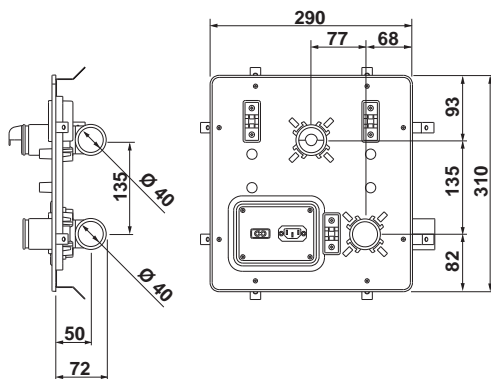

• 3.5 Description of the control panel

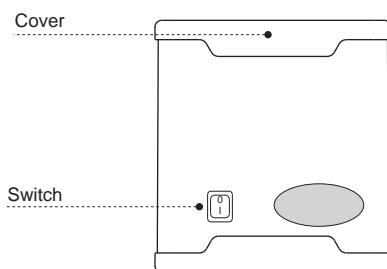

• Cover:

IMPORTANT!

NEVER use the central vacuum unit without its cover because the central vacuum capacity would be missing. Always make sure that it is properly installed, inserting the cover spigot in the central unit upper perimeter.

• Switch:

"I" (ON): the switch led turns on

The machine is on tension

"O" (OFF): the switch led turns off.

The machine is out of tension.

4 - INSTALLATION



**- ATTENTION -
THE FOLLOWING OPERATIONS MUST BE
CARRIED OUT BY QUALIFIED STAFF**



• 4.1 Safeguards

Here are some main rules to be followed in order to ensure a correct installation inside houses. Installation must foresee, upstream the central unit, a safety bipolar switch..

• 4.2 Area of installation

Installation of a central vacuum unit presumes the existence of an aspiration pipe network, installed by qualified staff that should also have spotted the best location for the central unit fixation template.

In case this was not carried out yet, following are some suggestions for a correct installation.

- If the central suction system has to be installed in multi-storey buildings, the suction unit must be located at the lowest level of the building.
- The central vacuum unit has to be installed in a service room (for example in a garage or in a storage room), sheltered from atmospheric agents and protected from moisture and temperature changes.
- Chose a space far from heat sources (burners or radiators).
- Provide spaces for the unit air flow entry and exit.

Foresee the air exhausting point outside the house, in a position that would not cause damage or nuisance to other buildings.

• 4.3 Installation spaces

Leave all around the central unit (approx 200 mm. each side) free and well-lit space to allow trouble-free maintenance operations, repairing, dust bag replacement and, at the same time, allow the air recycling and the motor cooling.

For any question do not hesitate to contact the Manufacturer Technical Assistance Service.

• 4.4 Installation applications

The central vacuum unit is fixed to an **installation template** that is usually prearranged, during the laying of the pipe network.

It allows the application on:

- walls
- wooden walls
- plaster walls

The wall on which the template will be installed must have the following characteristics:

- must be solid
- must be perfectly vertical
- must not be exposed to vibrations
- must be perfectly flat or the central unit will result instable

• 4.5 Installation template

The **installation template** is the central connecting support to the wall. It usually prearranged during the laying of the pipe network.

The installation template is connected to the vacuum and exhausting pipe network and the electrical connections to the micro line and to the power supply line.

NOTE:

- In case the template and the pipe network are already installed, verify the electric box installation.
- If also the electric box is already installed, go to the section "Fixing of the central unit to the installation template"

• In case the template has yet to be installed, carefully read the two following points. Accordingly to the kind of wall on which it will be installed, carefully follow the instructions hereafter.

• 4.6 Installation on walls

See illustrating sheet annexed to the instruction manual.

• 4.7 Installation on plaster or wooden walls

See illustrating sheet annexed to the instruction manual.



• 4.8 Electrical connection



- IMPORTANT -
BEFORE CARRYING OUT ANY CONNECTION
TURN OFF MAIN POWER SUPPLY..
- ATTENTION -
INSTALLATION MUST BE CARRIED OUT
EXCLUSIVELY BY QUALIFIED STAFF!



Before connecting to the power supply verify that voltage corresponds to the one required by the central vacuum unit.
 Power supply line must have cables with section diameter not less than 1.5 mm.². Do not connect the machine to a power line with excessive tension rush (ideal tension = local voltage \pm 10%).

Power the low voltage inlet signal with safe very low tension.

It is suggested, during central unit installation, to foresee, upstream the central unit itself, a safety bipolar switch.

The manufacturer declines any responsibility for damages to persons or objects resulting from connecting to an electric system not in compliance with the regulations in force.

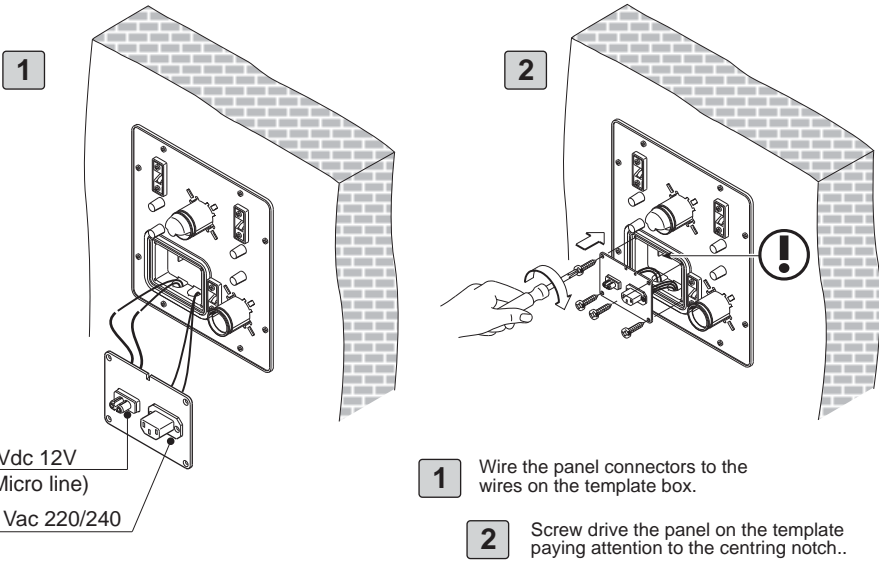

Vdc 12V
 (Micro line)
 ~ Vac 220/240

220/240V~ CE

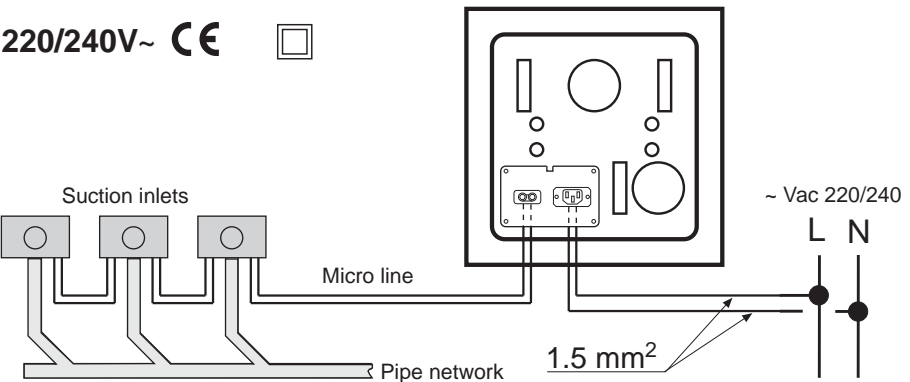

• 4.9 Fixing the central unit to the installation template

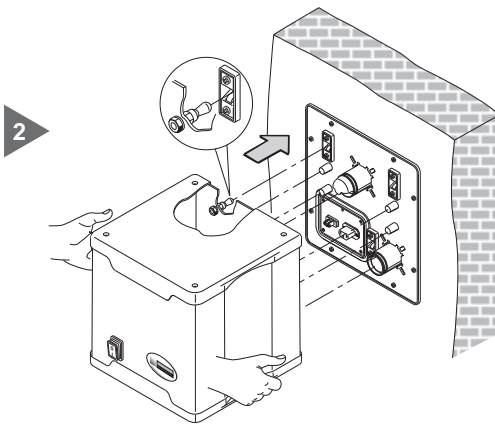
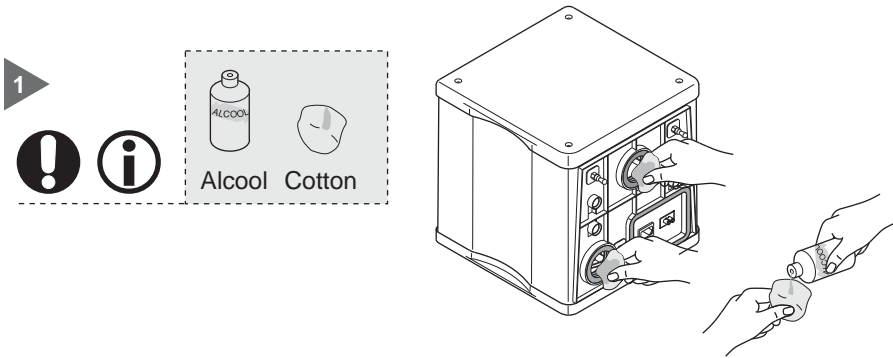

• 4.10 Disassembling the central unit from the installation template

NOTE: This operation must be carried out ONLY in case of real need, e.g. for extraordinary repairing.

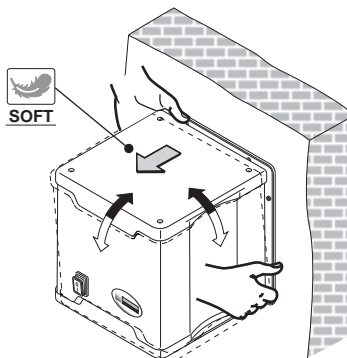

5 - HOW TO USE THE CENTRAL VACUUM UNIT

• 5.1 Starting the central vacuum unit

Put the main switch, located on the front of the central unit, to the position "I-ON"
The led on the switch will light, to indicate the central unit is powered on.

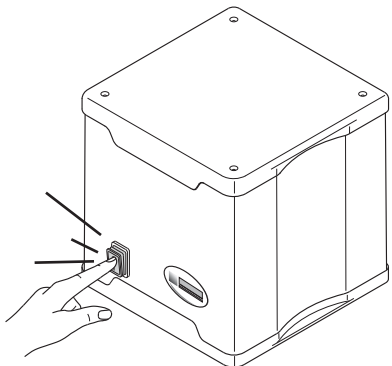

• 5.2 Use of the central vacuum unit

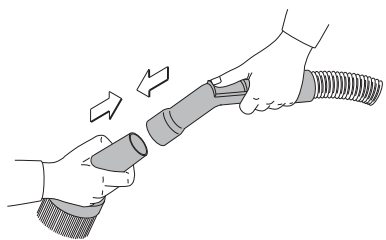

Fit the appropriate cleaning accessory on the flexible hose.

Starting

To start the machine, open a suction inlet.

- 1) Open a suction inlet and insert the flexible hose.
- The vacuum unit starts and the vacuuming begins.

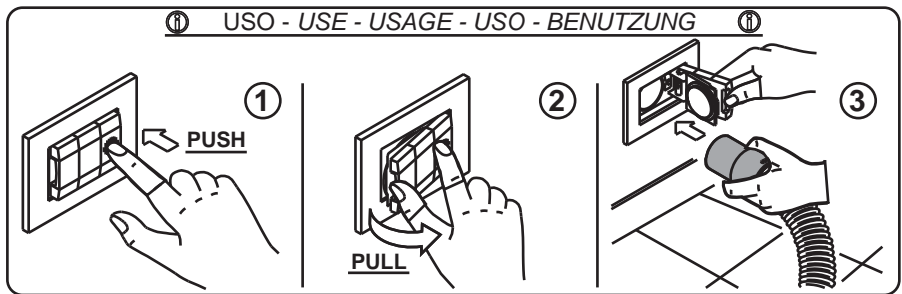

Turning off

- 1) To stop the machine, remove the flexible hose from the suction inlet.
- The central unit will stop automatically. NOTE: allow the central vacuum unit a few minutes to stop.

6 - MAINTENANCE



**- ATTENTION -
ALWAYS UNPLUG THE POWER SUPPLY CABLE FROM
THE POWER SUPPLY SOCKET AND ALWAYS WEAR
PROTECTION GLOVES AND GOGGLES BEFORE
CARRYING OUT ANY TECHNICAL OR
MAINTENANCE OPERATION**



• 6.1 Programmed maintenance

According to the accumulated operating time of the central vacuum system, it is necessary to carry out maintenance operations in order to keep the central unit always well performing and to avoid serious mechanical problems. It is suggested to carry out the following maintenance operations:

Frequency	Intervention	Carried out by
Dust bag full	Replacement of the dust bag	User
Each bag replacement	Cleaning of the filter cartridge	User
Once a year	Check the air exhaust obstruction	Assistance service

The casing of the suction unit needs periodically cleaning. Use a smooth and damp cloth with some neutral soap.

Attention: Be sure to use only water or water with neutral soap. Alcohol or other solvents may damage the unit. Wait until the unit is perfectly dry prior to start it.

• 6.2 Replacement of the dust bag

**- ATTENTION -
NEVER USE THE CENTRAL UNIT
WITHOUT THE DUST BAG**



Lift and remove cover

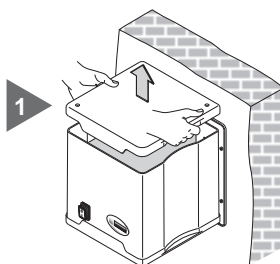

Remove the dust bag from the aspiration feed

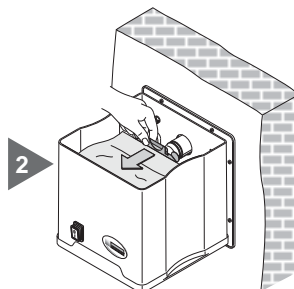

Close the bag

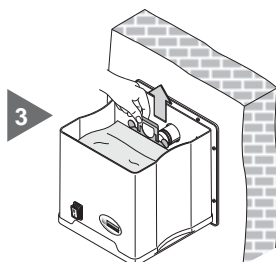

Gently remove the bag from the central unit.

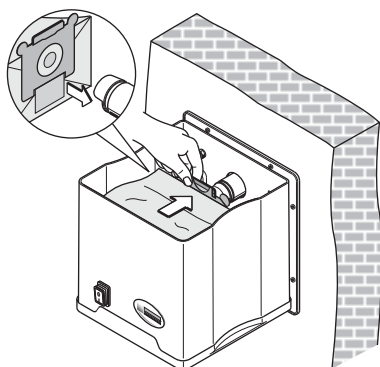
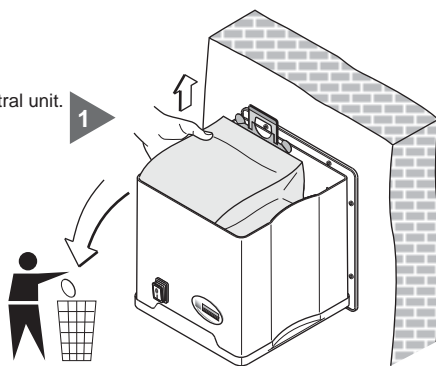

2 Place the new bag
ATTENTION: gently move back and forward
the bag so to fit the bag membrane into its slot

Reassemble the cover, checking that
the central body profile is perfectly
fitted into the cover indent.

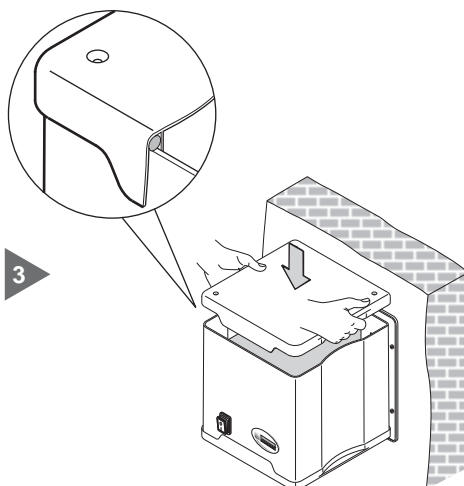

• 6.3 Replacement of the filter cartridge

- ATTENZIONE -
NEVER USE THE CENTRAL UNIT WITHOUT THE FILTER CARTRIDGE.



- Lift and remove cover (see previous paragraph)
- Remove dust bag (see previous paragraph)

Lift the filter cartridge from its seat

1

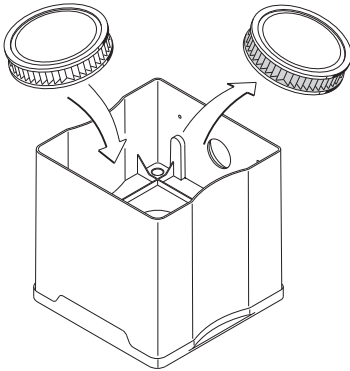
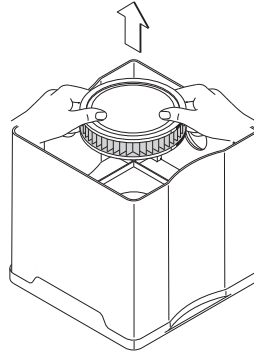

2

Replace the filter cartridge

Push the filter cartridge into its seat, until fixed

3

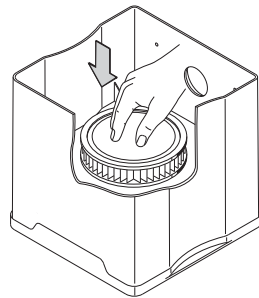

4

Reassemble dust bag and cover

• 6.4 Cleaning the filter cartridge

- ATTENTION-
NEVER USE THE VACUUM UNIT WITHOUT THE FILTER
CARTRIDGE BEFORE CARRYING OUT THE OPERATION
DESCRIBED HEREUNDER, ALWAYS ASSEMBLE A
NEW CARTRIDGE.



The filter cartridge can be washed with water
ATTENTION: before reassembling the filter make sure that it is completely dry



1

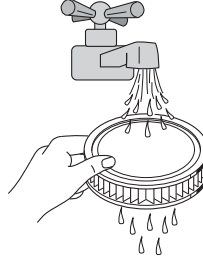

2

Check if the surface of the cartridge is torn; in this case, the filter cartridge cannot be used any longer.



7 - SERVICING

• 7.1 Servicing criteria

It is strictly forbidden to operate on the central suction unit to carry out any maintenance or servicing not mentioned (and therefore not allowed) in the user manual.

Only qualified providers of the technical assistance service can carry out any maintenance or repair operations. The guarantee will not apply in case of interventions carried out by non-authorized staff and the manufacturer cannot be considered responsible for possible injuries to persons and damages to things resulting from this kind of intervention.

8 - RECOMMENDED SPARE PARTS

• 8.1 Spare parts list

It is advisable to stock the spare parts more subject to wear. In order to guarantee the best performance of the central vacuum system, we suggest using only original spare parts. Please find below a list of spare parts.

Description	Quantity	Spare Part Code
Filter cartridge	1	See commercial brochure
Dust bag	Packing 10 Pieces	See commercial brochure

9 - DISMANTLING

• 9.1 General instructions

When dismantling the central suction system, dispose appropriately of used parts or material, which could endanger human health or well-being as well as the environment if handled improperly. You must be acquainted with sites/companies authorized to collect and dispose of used parts and materials. The disposal and/or recycling of any part of the suction system must be carried out in compliance with the legal regulations in force.



Disposal of Old Electrical & Electronic Equipment (Applicable in the European Union and other European countries with separate collection systems).

This symbol on the product or on its packaging indicates that this product shall not be treated as household waste. Instead it shall be handed over to the applicable collection point for the recycling of electrical and electronic equipment.

To reduce the environmental impact of WEEE (Waste electrical and Electronic Equipment) and minimize the volume of WEEE entering landfills, please reuse and recycle.

By ensuring this product is disposed of correctly, you will help prevent potential negative consequences for the environment and human health, which could otherwise be caused by inappropriate waste handling of this product. The recycling of materials will help to conserve natural resources. For more detailed information about recycling of this product, please contact your local city office, your household waste disposal service, the shop where you purchased the product, your local dealer or distributors.

10 - TECHNICAL PROBLEMES

• 10.1 Troubleshooting

Problem	Cause	Solution
No air suction in all air inlets	No power in the main supply line	Check for the cause upstream the central unit
	Central unit main switch is on the "OFF" position	Bring the main switch on to the "I-ON" position
	The central unit is not correctly connected to the wall template	Check the connection between the central unit and the plate
	The thermal relay of the motor does not work	Leave the motor cooling down for a few minutes
No air suction in only one inlet	The power supply contacts are cut off or the microswitch of the inlet does not work	Contact the Assistance Service
Weak air suction	Several suction inlets are used simultaneously	Use only one suction inlet at a time
	The hose or the cleaning accessories are broken/damaged	Check the integrity of the flexible hose and accessories and replace them if necessary
	The filter cartridge is dirty	Clean or replace the filter cartridge
	Top cover damaged or out of place	Check the cover integrity and correct placing
	Dust bag out of place or full	Check the correct positioning of the dust bag. If full, replace it..
	The pipes of the suction system are obstructed	Contact the Assistance Service
	Air exhaust pipes are obstructed	Contact the Assistance Service
The central vacuum unit keeps running even when the suction inlets are closed	The micro switch of a single inlet does not work	Turn off the central unit and contact the Assistance Service

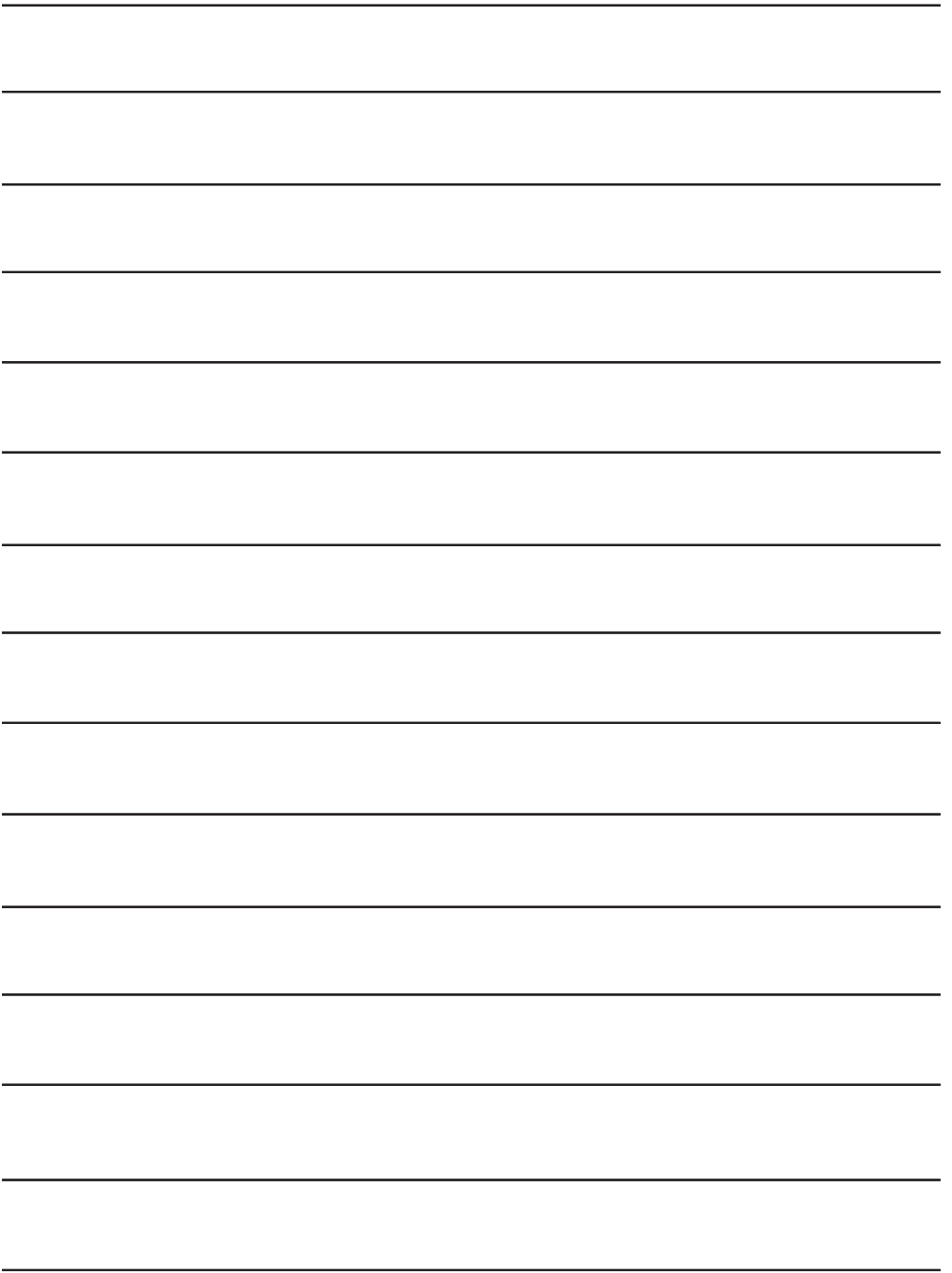



Register your warranty

Registra la tua garanzia
Enregistrez votre garantie
Registrieren Sie Ihre Garantie
Registre su garantía

sistemair.it/registrazione-prodotto



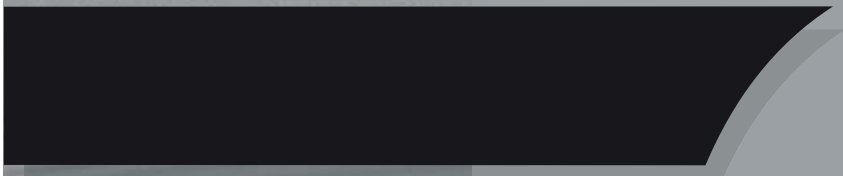

F0920043

www.sistemair.it

27020 Gravellona Lomellina (PV) ITALIA Via Cilavegna, 53
Tel. +39 0381 650082 - Fax +39 0381 650120 - info@sistemair.it