



CENTRAL VACUUM SYSTEMS

# PRICE LIST <sup>23-1</sup>





# INDEX

## DOMESTIC

### TRADITIONAL LINE

Tecno Prime	5
Tecno Evox	8

### MINI LINE

Tecno Style Mini	10
------------------	----

### FLATS

Wolly 2	12
Sistem Cube	14

### LARGE HOUSES

Tecno Star Dual Power	16
-----------------------	----

## PROFESSIONAL

### BASIC COMPACT UNITS

Revo Job	18
----------	----

### DIGITAL COMPACT UNITS

Revo Block professional	20
-------------------------	----

## INDUSTRIAL

### DUST SEPARATOR

Industrial clean	22
Basic separator	24

### MOTORS

Matic line	26
Basic line	28

### SELF-CLEANING FILTER

Maxicleaner	30
Autocleaner	30

### CYCLONIC PRE-SEPARATOR

Turbix	32
Auto Jet Turbix	34

### MOTORISED HOSE REEL

Roll Flex	36
-----------	----

### INDUSTRIAL COMPLEMENTS

Master Line Professional	38
--------------------------	----

## INLET VALVES

Main features	41
---------------	----

### RECTANGULAR

Virtus	42
Generation	44

### SQUARED

Standard	46
Design	46

### SPECIAL

Vacpan	47
Floor	47
Outdoor	47
Industrial	47

## INSTALLATION MATERIAL

### PVC

Main features	49
Installation kit	50
Installation for standard system	51
Test	54
Remote connection	55

### STEEL

Main features	56
Industrial installation	58

### SENSE RETRACTABLE HOSE SYSTEM

Main features	61
Installation for retractable system	62
Sense accessories	63

## ACCESSORIES AND SPARE PARTS

Main features	65
---------------	----

### DOMESTIC CLEANING ACCESSORIES

Natural Trendy brushes	66
Standard brushes	67
Pipes and fittings	68

### PROFESSIONAL CLEANING ACCESSORIES

Oven Cleaning Kit	70
Brushes	71
Pipes and fittings	71

### CLEANING KIT

On/Off wireless Flisy 2	72
Standard	73

### SPECIAL SEPARATOR

Liquid and ash separators	74
---------------------------	----

### SPARE PARTS

Filters	76
Bags	78

## SPARE PARTS

Cleanoop  
EASY CLEAN SHOP

cleanoop.com



# How the central vacuum system works

Detached houses, flats or small studios. Any building deserves to have the best cleaning system for those who live in it.

Not even small spaces or aesthetic constraints should be an obstacle to well-being. That is why a central vacuum system is for everyone.

## Powerful, light and... clean that lasts longer

The central vacuum system radically changes the concept of cleaning. A revolution that starts with the inlet valves into which the vacuum hose is inserted, they are discreet and identical to the chosen interior design.

They are connected to each other by a pipe network that has the task of conveying the vacuumed material. It is realised underneath the ceiling, embedded in the false ceiling or, in the case of already finished homes, concealed with decorative plasterboard.

**A central vacuum cleaner, either of the traditional type or built-in outside, collects the dirt in the dust container, without ever coming into contact with the user.**

Lastly, as there is no recirculation of the vacuumed air in the room, the clean lasts longer. Saving time and effort.



A. Pipe network



B. Inlet Valves



C. Central vacuum cleaner

## Living in a healthy house

The powerful suction of the system removes all traces of dirt and eliminates dust mites, allergens, dust pollutants, bacteria and viruses thanks to the external vent.



Micro-dust is expelled from the house through an external vent.

The exhaust air is pre-filtered. Only invisible particles, normally present in the air, are released into the atmosphere.





A

B

Always connected



# Tecno Prime

## Central vacuum cleaner

Field of application:

domestic

houses, villas, shops



Max. surface to be cleaned: **450 m<sup>2</sup>**

1 single user



Pipe network Ø 50 mm



IP44



Tecno Prime is **the first internet-connected central vacuum cleaner** with Air Cloud personal maintenance assistant and 6-years kasko insurance.

Touch display and an innovative BiVac system offer a **choice between bag filtration or the low-maintenance cyclonic filtration.**

The Tecno Prime range of central vacuum cleaners is **specifically designed for domestic dust extraction.**

Available in **four motorisation** to clean the surfaces **up to 450 m<sup>2</sup>** for system used by a single user.



Learn more about  
Tecno Prime

Maximum surface to clean	Model	Article	Recommended inlet valves	Pkg	UM	Price
150 m <sup>2</sup>	Tecno Prime 150	3110.2TPR	4	1	pc	€ 1.610,00
250 m <sup>2</sup>	Tecno Prime 250	3112.2TPR	7	1	pc	€ 1.790,00
350 m <sup>2</sup>	Tecno Prime 350	3113.3TPR	11	1	pc	€ 2.020,00
450 m <sup>2</sup>	Tecno Prime 450	3115.3TPR	16	1	pc	€ 2.280,00

# Technical features

## FEATURES

- Self-supporting cylindrical polipropylene and ABS body
- 21 l polypropylene dust container with PA6 nylon handles
- Soundproof motor compartment
- Single-phase brush-type electric motor
- Vacuum breaker valve
- Antistatic, class M certified filter
- Double protection electric control board, with fuses both on the main and secondary circuit
- On-board touch screen computer
- Pressure transducer to measure the efficiency status of the filter and dust bag level
- Soft Start system integrated in the microprocessor board
- Safety temperature sensor protection requiring manual reset
- Ethernet socket for Air Cloud internet connection
- On-board inlet valve - only with cyclonic filtration
- Reversible system connection Rt/Lh

# Technical data

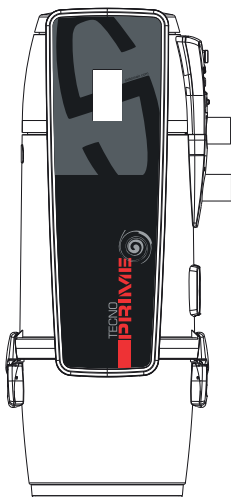

MODEL	Tecno Prime			
	150	250	350	450
ARTICLE	3110.2TPR	3112.2TPR	3113.3TPR	3115.3TPR
<b>Micro-dust vent</b> 	<b>YES</b>	<b>YES</b>	<b>YES</b>	<b>YES</b>
Computer maintenance	YES	YES	YES	YES
Air inlet/Air discharge	Ø mm	50	50	50
Power supply	V ac	220/240	220/240	220/240
Frequency	Hz	50/60	50/60	50/60
Motor power	kW	1,25	1,35	1,45
Absorption	A	5,0	5,6	6,3
Inlet valves power supply	V dc	12	12	12
Maximum air flow	m <sup>3</sup> /h	200	234	240
Maximum depression	mbar	274	272	310
Filtration class		M	M	M
Filtering surface	cm <sup>2</sup>	6700	6700	6700
Dust container capacity	l	21	21	21
BiVac bag capacity	l	18	18	18
Air exhaust silencer Ø 50 mm		YES	YES	YES
Weight	kg	17	17	17
Width	mm	380	380	380
Depth	mm	412	412	412
Height	mm	919	919	919
Minimum height from ground	mm	100	100	100
Noise level lower than	dB(A)	70		

**P.N.:** Rated noise values, may vary depending on environment and type of installation.



## Main features

### Antistatic filter

The filter is free from static charge build-up thanks to its connection to the plant's earthing system. The inverted conical shape, at the end of the vacuum process, allows everything that has settled on the surface of the filter to fall into the dust container. Washable and M class certified.



### BiVac: choice of cyclonic or bag filtration

Tecno Prime comes complete with the BiVac kit necessary to choose between two filtration options during installation.

**Cyclonic filtration** The vacuumed dust is filtered and separated from the air by the cyclone and falls into the dust container. With this configuration it is possible to use the inlet valve on the machine.

**Bag filtration** The microfibre bag retains the suctioned dust, making the filter cleaning unnecessary. With this configuration the inlet valve on the machine must be discarded.



### Intelligent maintenance computer

From the touch display it is possible to access the functions dedicated to installation. This allows, through tests, to verify the correct functioning of the installation.

Also, maintenance intervals can be programmed, filter efficiency can be checked as also the dust container level.



### Air Cloud Personal Maintenance Assistant

Air Cloud is the heart of the Tecno Prime central vacuum cleaner: it monitors health and prevents possible malfunctioning. An alert warns in the event of anomalies and you can choose whether to receive alerts directly or send them to your maintenance technician.

**By keeping the Tecno Prime central vacuum always connected to the network, you get 6 year kasko cloud warranty.**



### On-board valve

On the vacuum body, there is a inlet valve for cleaning rooms adjacent to the point of installation (e.g. garages, cellars, etc.).

Always ready to use, simply insert the hose and start vacuuming from the display.



# Tecno Evox

## Central vacuum cleaner

Field of application:

domestic  
houses, villas, shops



Max. surface to be cleaned: **450 m<sup>2</sup>**

1 single user



Pipe network Ø 50 mm



IP20



**Tecno Evox is designed for a user who does not want to compromise on quality**, underlined by the materials chosen and the careful assembly.

Power and reliability for those who seek an essential product but are not willing to compromise.

Available in **four motorisations** to clean surfaces **up to 450 m<sup>2</sup>** for system used by a single user.

### FEATURES

- Self-supporting cylindrical polypropylene and ABS body
- 21 l polypropylene dust container with PA6 nylon handles
- Soundproof motor compartment
- Single-phase brush-type electric motor
- Vacuum breaker valve
- Class M certified filter
- Double protection electric control board, with fuses both on the main and secondary circuit.
- Soft Start system integrated in the microprocessor board
- Safety temperature sensor protection requiring manual reset
- On-board inlet valve
- Reversible system connection Rt/Lh



Learn more about  
Tecno Evox

Maximum surface to clean	Model	Article	Recommended inlet valves	PKG	UM	Price
150 m <sup>2</sup>	Tecno Evox 150	3110.1TEV	4	1	pc	€ 1.490,00
250 m <sup>2</sup>	Tecno Evox 250	3112.1TEV	7	1	pc	€ 1.670,00
350 m <sup>2</sup>	Tecno Evox 350	3113.3TEV	11	1	pc	€ 1.890,00
450 m <sup>2</sup>	Tecno Evox 450	3115.3TEV	16	1	pc	€ 2.150,00

# Main features

## Reversibility of connections

Tecno Evox is designed to easily connect the IN input and OUT discharge to the pipe network, either left or right.



## Vacuum breaker valve

The vacuum breaker valve opens automatically, supplying air to the motor when the flow from the intake pipe is reduced or absent, anticipating the intervention of the thermal protection.



## Ergonomy and simplicity

Designed to be easy to use, it adopts a dust container with easy-to-operate hooks that act as handles to carry the dust container to the emptying point.



## On board inlet valve

On the body, there is an inlet valve for cleaning rooms adjacent to the point of installation (e.g. garages, cellars, etc.). It is activated by pressing the 0/I switch on the front of the central vacuum cleaner.

# Technical data

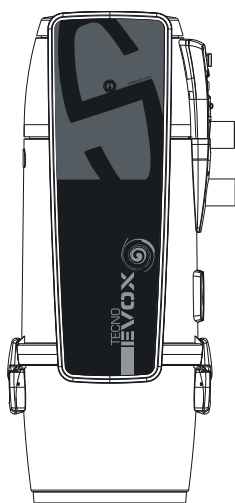

MODEL	Tecno Evox				
	150	250	350	450	
ARTICLE	3110.1TEV	3112.1TEV	3113.3TEV	3115.3TEV	
<b>Micro-dust vent</b> 	<b>YES</b>	<b>YES</b>	<b>YES</b>	<b>YES</b>	
Air inlet/Air discharge	Ø mm	50	50	50	50
Power supply	V ac	220/240	220/240	220/240	220/240
Frequency	Hz	50/60	50/60	50/60	50/60
Motor power	kW	1,25	1,35	1,45	1,50
Absorption	A	5,0	5,6	6,3	6,7
Inlet valves power supply	V dc	12	12	12	12
Maximum air flow	m³/h	200	234	240	180
Maximum depression	mbar	274	272	310	400
Dust container capacity	l	21	21	21	21
Weight	kg	17	17	17	18
Width	mm	380	380	380	380
Depth	mm	412	412	412	412
Height	mm	919	919	919	919
Minimum height from ground	mm	100	100	100	100
Noise level lower than	dB(A)	70			

**P.N.:** Rated noise values, may vary depending on environment and type of installation.

# Tecno Style Mini

## Central vacuum cleaner

Field of application:

domestic  
houses, flats, small spaces



Max. surface to be cleaned: **150 m<sup>2</sup>**

1 single user



Pipe network Ø 50 mm



IP44



Tecno Style Mini is a powerful concentrate for installations in small spaces.

Even if smaller, suction power and comfort is kept. For those who do not want to compromise.

The Tecno Style Mini central vacuum cleaner is **designed specifically for domestic dust suction**.

Available in **single motorisation** with Mini body to clean surfaces **up to 150 m<sup>2</sup>** for system used by a single user.

### FEATURES

- Self-supporting cylindrical polypropylene and ABS body
- 15 l polypropylene dust container with PA6 nylon handles
- Soundproof motor compartment
- Single-phase brush-type electric motor
- Vacuum breaker valve
- Class M certified filter
- Double protection electric control board, with fuses both on the main and secondary circuit
- Soft Start system integrated in the microprocessor board
- Safety temperature sensor protection requiring manual reset
- Reversible system connection Rt/Lh

TECNO STYLE  
MINI



Learn more about  
Tecno Style Mini

Maximum surface to clean	Model	Article	Recommended inlet valves	Pkg	UM	Price
150 m <sup>2</sup>	Tecno Style MINI	3107.1TER	4	1	pc	€ 1.060,00

## Main features

### Compact dimensions

Tecno Style Mini offers all the power and effectiveness of cyclonic dust separation. The body of the central vacuum cleaner measures only 65 cm in height and 34 cm in depth.

The ideal choice for balconies, basements, hallways, wardrobes, small commercial spaces or other confined environments.



### Reversible connections

Tecno Style Mini is designed to easily connect the IN input and OUT discharge to the pipe network, either left or right.



### Compact filter

Tecno Style Mini is equipped with a high-performance, washable compact filter class M certified.



### Ergonomicity and simplicity

Designed to be easy to use, it has a dust container with hooks that act as handles to carry the container to the emptying point.

## Technical data

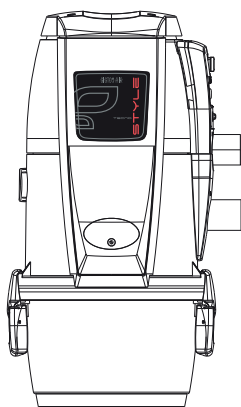

MODEL		Tecno Style Mini
ARTICLE		3107.1TER
<b>Micro-dust vent</b> 		<b>YES</b>
Air inlet/Air discharge	Ø mm	50
Power supply	V ac	220/240
Frequency	Hz	50/60
Motor power	kW	1,25
Inlet valves power supply	V dc	12
Maximum air flow	m³/h	200
Maximum depression	mbar	274
Dust container capacity	l	15
Weight	kg	8,5
Width	mm	340
Depth	mm	345
Height	mm	650
Minimum height from ground	mm	100
Noise level lower than	dB(A)	70

**P.N.:** Rated noise values, may vary depending on environment and type of installation.

# Wolly 2

## Central vacuum cleaner

Field of application:

domestic  
flats, buildingsMax. surface to be cleaned: **300 m<sup>2</sup>**

1 single user



Pipe network Ø 50 mm



IP44



Wolly 2 is the ideal built-in **central vacuum cleaner for flats**. Super quiet and so compact that it fits everywhere.

**Compatible with stringent energy and acoustic certifications** thanks to the high-density polystyrene body that maintains the insulation of the wall where it is recessed.

Clean lines for a discreet aesthetic that blends in with any architectural design.

### FEATURES

- PP-ABS plastic body
- Sound-absorbing case
- Microfibre filter bag (12 l capacity)
- Soundproof motor dome
- Single-phase brush-type electric motor
- Vacuum breaker valve
- Class M certified filter
- Soft Start system integrated in the microprocessor board
- Safety temperature sensor protection requiring manual reset
- Reversible system connection Rt/Lh



Learn more about  
Wolly 2

Maximum surface to clean	Model	Article	Recommended inlet valves	Pkg	UM	Price
150 m <sup>2</sup>	Wolly2 150	<b>8201.0</b>	<b>4</b>	1	pc	<b>€ 1.070,00</b>
300 m <sup>2</sup>	Wolly2 300	<b>8201.1</b>	<b>7</b>	1	pc	<b>€ 1.130,00</b>

# Main features

MODEL		Wolly 2 - 150	Wolly 2 - 300
ARTICLE		8201.0	8201.1
<b>Micro-dust vent</b>		<b>YES</b>	
Air inlet/Air discharge	Ø mm	50	
Power supply	V ac	220/240	
Frequency	Hz	50/60	
Motor power	kW	1,25	1,35
Maximum air flow	m³/h	200	234
Maximum depression	mbar	274	272
Inlet valves power supply	V dc	12	
Dust container capacity	l	12	
Width	mm	430	
Height	mm	630	
Depth	mm	187	
Noise level lower than	dB(A)	70	

**P.N.:** Rated noise values, may vary depending on environment and type of installation.



## Built-in

At only 18.7 cm deep, it combines with the aesthetics of the building façade.



## Wall-mounted

Wolly 2 can also be installed against a wall.

## A All inclusive art. 8201.0 e art 8201.1

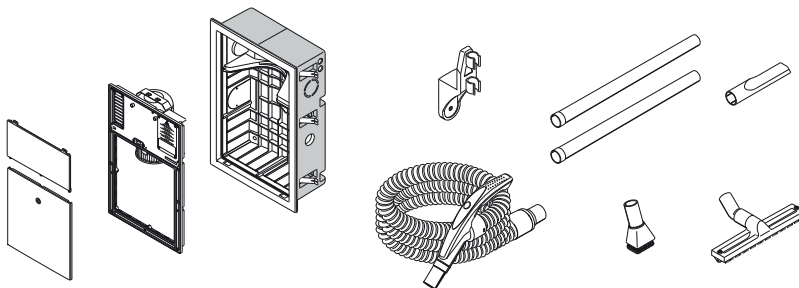

The kit includes:

- central vacuum cleaner Wolly 2
- motor module (by choice up to 150 m² or 300 m²)
- Built-in box
- cleaning kit.

Wolly 2 comes with a kit for the main cleaning tasks.

In addition, the Mini accessory hook allows neat storage of the hose and accessories.

## B Only predisposition

### Built-in installation



Article	Description	Pkg	UM	Price
7102.1	Built-in box Wolly 2	1	pc	€ 236,00

### Wall mounting installation



Article	Description	Pkg	UM	Price
7102.2	Outdoor installation frame Wolly 2	1	pc	€ 180,00



7102.1	Built-in Wolly 2*	1	pc	€ 236,00
--------	-------------------	---	----	----------

\*for wall mounting, insert the built-in box art. no. 7102.1 inside the frame

## C Finishing



Article	Description	Pkg	UM	Price
8202.0	Suction module/motor Wolly 2 mod. 150	1	pc	€ 720,00
8202.1	Suction module/motor Wolly 2 mod. 300	1	pc	€ 770,00

# Sistem Cube

## Central vacuum cleaner

Field of application:

domestic  
flats and micro spaces



Max. surface to be cleaned: **120 m<sup>2</sup>**

1 single user



Pipe network Ø 50 mm



IPX4



Sistem Cube is the world's smallest **central vacuum cleaner for cleaning spaces up to 120 m<sup>2</sup>** for system used by a single user.

A concentrate of **healthiness and cleaning power that integrates into the under-sink** or any available space thanks to its **compact dimensions of 30x28x30 cm**.

The **pre-wired template** makes installation quick and convenient. Squared design makes it elegant and discreet, the invisible cleaning companion.

The Sistem Cube central vacuum cleaner is **specifically designed for domestic dust vacuuming**.

### FEATURES

- PP-ABS plastic body
- Dust filtering bag
- Motor safety filter
- Single-phase electric motor
- Soft Start system integrated in the microprocessor board
- Safety temperature sensor protection requiring manual reset
- Reversible system connection Rt/Lh



Learn more about  
Sistem Cube

Maximum surface to clean	Model	Article	Recommended inlet valves	Pkg	UM	Price
Max 120 m <sup>2</sup>	Sistem Cube	8300.0	3	1	pc	€ 990,00

**P.N.:** Pre-wired template to be purchased separate.



# Main features

MODEL	Sistem Cube	
ARTICLE	8300.0	
<b>Micro-dust vent</b> 	<b>YES</b>	
On-board vacuum valve	NO	
Air inlet/Air discharge	Ø mm	40*
Power supply	V ac	220/240
Frequency	Hz	50/60
Motor power	kW	1
Inlet valves power supply	V dc	12
Maximum air flow	m³/h	178
Maximum depression	mbar	245
Dust container capacity	l	15
Weight	kg	4
Width	mm	280
Height	mm	300
Depth	mm	300
Noise level lower than	dB(A)	70

**P.N.:** Rated noise values, may vary depending on environment and type of installation.

\*the eccentric increase item 5040.1 must be purchased separately



## Outdoor installation

The IPX4 degree of protection allows Sistem Cube to be installed outdoors without contraindications. When arranging the tubing and the pre-wired template, take the desired positioning into account.



## Indoor installation

The compact dimensions of Sistem Cube allow it to be installed anywhere, even inside furniture. The chosen room can be without ventilation, as the direct cooling motor uses air from the inlet valves.

## All inclusive Sistem Cube with cleaning kit included

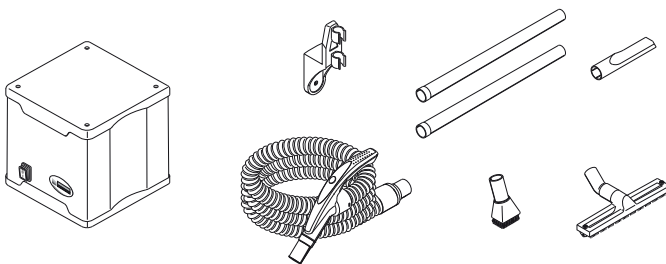

The kit includes:

- brush for floors and hard surfaces
- corner lance
- dusting brush.

Sistem Cube is supplied with a kit for the main domestic cleaning tasks.

In addition, the Mini accessory hook allows neat storage of the hose and accessories.



Article	Description	Pkg	UM	Price
8300.10	Wall pre-wired template for Sistem Cube*	1	pc	€ 97,00

\*To be purchased separately

# Tecno Star Dual Power

## Central vacuum cleaner

Field of application:

domestic



large houses, semi-detached villas,

B&Bs, shops, small workshops

Max. surface to be cleaned: **450 m<sup>2</sup>**

up to 2 users

Pipe network Ø 63 mm



IP20



Tecno Star Dual Power is the domestic central vacuum cleaner that allows **up to 2 users to use the system at the same time.**

Semi-professional core, powered by a pair of brush motors, and **predisposed for the integration of the Autocleaner automatic filter cleaning system.**

Ideal for spacious houses **up to 450 m<sup>2</sup>, two-family solutions, bed & breakfasts and shops.**

### FEATURES

- Cylindrical epoxy powder-coated body
- Shock-proof coated base
- 62 l metal dust container on wheels
- Bag tightener
- Single-phase electric motor
- Soundproofing for each individual motor
- Vacuum breaker valve
- Class M certified filter
- Filter protection flange
- Double protection electric control board, with fuses both on the main and secondary circuit
- On-board computer
- Soft Start system integrated in the microprocessor board
- Provision for Autocleaner automatic filter cleaning system
- Reversible system connection Rt/Lh

TECNO **Star**  
Dual Power



Learn more about  
Tecno star

Maximum surface to clean	Model	Article	Recommended inlet valves	Pkg	UM	Price
450 m <sup>2</sup>	Tecno Star Dual Power	3116.2TS	16	1	pc	€ 4.550,00

# Main features

## On board intelligent computer

The electronic board with microprocessor connected to the pressure sensors can provide real-time readings. Tecno Star Dual Power detects:

- dust container level
- filter consumption status
- general efficiency level of the system
- vacuum pressure value in the system
- scheduled maintenance
- switch-on hours
- power consumption



## Filter protection flange

A steel flange is attached to the body of the central vacuum cleaner to protect the filter. This protects the filter cartridge from wear and tear even when sucking in large amounts of dust or in the presence of abrasive residue.



## Dust container on wheels

The Tecno Star Dual Power dust container is equipped with wheels that make it easy to move it to the emptying point.

It is equipped with a simplified release system, with a handle covered in shockproof material, which allows the dust container to be emptied effortlessly.



## Autocleaner automatic filter cleaning system

Tecno Star Dual Power is predisposed for installation of the Autocleaner system, art. no. 3600.0U (optional to be purchased separately), for automatic filter cleaning. For more details see Autocleaner section page 30

# Technical data

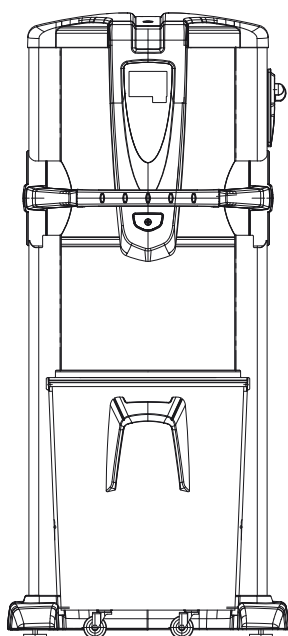

### MODEL

Tecno Star Dual Power

### ARTICLE

3116.2TS

### Micro-dust vent

**YES**

Computer maintenance

YES

Air inlet/Air discharge

Ø mm

63

Power supply

V ac

220/240

Frequency

Hz

50/60

Motor power

kW

1,35 x 2

Inlet valves power supply

V dc

12

Maximum air flow

m<sup>3</sup>/h

390

Maximum depression

mbar

285

Dust container capacity

l

62

Weight

kg

55

Width

mm

615

Height

mm

1369

Depth

mm

600

Noise level with 1 motor

dB(A)

64

Noise level with 2 motors

dB(A)

69

**P.N.:** Rated noise values, may vary depending on environment and type of installation.

# Revo Job

## Central vacuum cleaner

Field of application:

professional  
workshops, garages, tyre shops,  
accommodation facilities



Max. surface to be cleaned: **3000 m<sup>2</sup>**

up to 3 users



Pipe network Ø 63 mm - Ø 80 mm



IP20



Heavy  
duty

Revo Job is the professional central vacuum cleaner for up to 3 users at the same time.

Professional, maintenance-free motor for maximum reliability. Automatic filter cleaning system by vibration included.

Ideal for large areas and professional applications where a compact central vacuum cleaner is required.

### FEATURES

- Epoxy powder-coated metal body and base, coated with impact-resistant material
- 70 l metal dust container on wheels
- Bag tightener
- Side channel motor-pump unit, with light alloy casing, high performance and maintenance-free
- Automatic adjustment of vacuum power-inverter (Revo Job 4 kW only)
- Vacuum breaker valve
- Class M certified filter
- Filter protection flange
- Automatic filter cleaning system by vibration
- Thermal magnetic protection
- Reversible system connection Rt/Lh



Learn more about  
Revo Job

Maximum surface to clean	Model	Article	Recommended inlet valves	Pkg	UM	Price
Max 2000 m <sup>2</sup>	Revo Job 3 kW	3201.2J	2	1	pc	€ 7.100,00
Max 3000 m <sup>2</sup>	Revo Job 4 kW	3201.6J	3	1	pc	€ 9.750,00

\*Check with the technical department for conditions of use.

# Main features

## Filter protection flange

A steel flange is attached to the body of the central vacuum cleaner to protect the filter. This protects the filter cartridge from becoming worn out even when sucking in large amounts of dust or in the presence of abrasive residue.



## Vibration self-cleaning

Filter cleaning system by means of vibration cycles of the filter cartridge that are activated each time the vacuum is switched off. Allows reduction of the cleaning frequency of the filter surface.



## Strong and essential

The construction solutions adopted make it an extremely rational machine, designed for particularly heavy-duty situations, where electronic management of performance is not fundamental, preferring robustness and simplicity of use. Even in the 4 kW version, equipped with an inverter with a selection of three suction powers, the control board on the central unit makes switching the suction power as simple as possible.



# Tecnical data

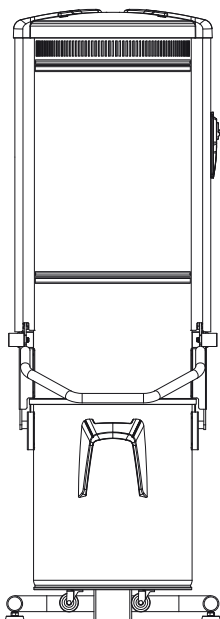

Model	Revo Job 3		Revo Job 4
	Article		3201.6J
Intake connection	Ø mm	80	80
Exhaust air	Ø mm	80	80
Power supply	V ac	400	400
Frequency	Hz	50/60	50/60
Motor power	kW	3	4
Inlet valves power supply	V dc	12	12
Electronic speed converter		NO	YES
Maximum air flow	m <sup>3</sup> /h	414	570
Automatic filter cleaning by vibration		YES	YES
Dust container capacity	l	70	70
Air vent		YES	YES
Weight	kg	100	105
Width	mm	570	570
Height	mm	1625	1625
Depth	mm	630	630
Motor noise	dB(A)	60÷80	

**P.N:** Rated noise values may vary depending on the environment in which the control unit is installed and the type of installation

# Revo Block professional Central vacuum cleaner

Field of application:

professional

workshops, accommodation

facilities, office buildings, large villas



Max. surface to be cleaned: **3000 m<sup>2</sup>**

up to 3 users



Pipe network Ø 63 mm - Ø 80 mm



IP20



With  
management  
computer



Revo Block is the professional central vacuum cleaner that allows **up to 3 users at the same time**.

Optimised consumption thanks to suction power management.

## FEATURES

- Cylindrical epoxy powder-coated body
- Shock-proof coated base
- 80/106 l metal dust container
- Bag tightener
- Side-channel motor-pump ground with light alloy case, high performance and maintenance-free
- Automatic adjustment of vacuum power - inverter (except Revo Block 700 Plus)
- Touch screen on-board computer
- Mechanical breaker valve
- Class M certified filter
- Filter protection flange
- Possibility to combine with Autocleaner, the automatic filter cleaning system
- Thermal magnetic protection
- Reversible system connection Rt/Lh

REVO BLOCK  
professional



Learn more about Revo  
Block Professional

Maximum surface to clean	Model	Article	Maximum number of user	Pkg	UM	Price
Max 700 m <sup>2</sup>	Revo Block 700 Plus	<b>3213.2B</b>	2	1	pc	€ 8.100,00
Max 1000 m <sup>2</sup>	Revo Block 1000	<b>3203.3B</b>	2	1	pc	€ 8.350,00
Max 1200 m <sup>2</sup>	Revo Block 1200	<b>3203.4B</b>	2	1	pc	€ 8.700,00
Max 1500 m <sup>2</sup>	Revo Block 1500	<b>3203.5B</b>	2	1	pc	€ 10.100,00
Max 1800 m <sup>2</sup>	Revo Block 1800	<b>3203.6B</b>	3	1	pc	€ 11.600,00

It can be combined with (page 30)

# Main features

## Touch Screen user interface

A real computer that manages all the control unit's functions: adjustment of suction power, energy saving, operating parameters and maintenance alerts.

With the possibility of connecting the control unit to a remote PC, present on the same network, to remotely monitor the control unit (Master Control system, optional, see page 55)

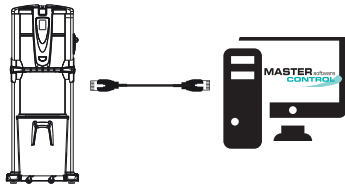

## Soft touch container release mechanism

You don't need your strength, just Sistem Air's. We have developed a dust container release mechanism that guarantees solidity and a perfect hold without requiring any effort to release and hook the container.



## Compact without sacrificing performance

It is a compact unit, but thanks to its professional motor and intelligent performance management it has all the features to be used on large surfaces even with several users at the same time. The possibility of fitting the automatic filter cleaning system using compressed air (Autocleaner, optional on page 30) completes the PRO soul of this central unit.

# Tecnical data

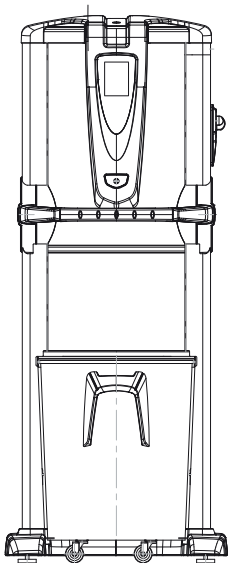

Model		Revo Block 700 Plus	Revo Block 1000	Revo Block 1200	Revo Block 1500	Revo Block 1800
Article		3213.2B	3203.3B	3203.4B	3203.5B	3203.6B
Computer maintenance		YES	YES	YES	YES	YES
Intake connection	Ø mm	63(*)	63(*)	63(*)	63(*)	80
Air exhaust	Ø mm	63	63	63	63	80
Power supply	V ac	400	220/240	400	400	400
Frequency	Hz	50/60	50/60	50/60	50/60	50/60
Motor power	kW	3	2,2	2,2	4	4
Inlet valves power supply	V dc	12	12	12	12	12
Speed electronic converter		NO	YES	YES	YES	YES
Maximum air flow	m³/h	400	366	366	471	570
Dust container capacity	l	106	106	106	106	106
Air vent		YES	YES	YES	YES	YES
Weight	kg	95	95	95	105	115
Width	mm	750	750	750	750	750
Height	mm	1616	1616	1616	1616	1616
Depth	mm	750	750	750	750	750
Motor noise	dB(A)	60÷80				

**P.N:** Rated noise values may vary depending on the environment in which the control unit is installed and the type of installation

\*models supplied with increase 63/80 to connect the control unit to the pipework.

# Industrial Clean Separators

Field of application:

industrial

hotels, industries, museum, cinemas,  
shopping centres



Max. surface to be cleaned: **unlimited**

Up to 8 users



Pipe network Ø 80 mm - Ø 100 mm



IP20



With  
management  
computer



The dust separators of the Industrial Clean line have an on-board computer that is able to control the entire industrial vacuum unit.

Each separator can control up to 8 motors, allowing large areas to be covered with maximum efficiency and simplicity in a single system.

Vacuumed material is collected to minimise maintenance operations

## FEATURES

- Cylindrical epoxy powder-coated body
- Shock-proof coated base
- Metal dust container with wheels (capacity 80/106 litres)
- Bag tightener
- On-board touch screen computer
- Mechanical breaker valve
- Class M certified filter
- Filter protection flange
- Possibility to combine with Autocleaner, the automatic filter cleaning system (see on page 30)
- Reversible system connection Rt/Lh

## Industrial Clean



Learn more about  
Industrial Clean

Model	Article	Maximum numbers of users with flexible hose Ø 32	Maximum numbers of users with flexible hose Ø 40	Pkg	UM	Price
Industrial Clean Small	3403.0	4	3	1	pc	€ 4.050,00
Industrial Clean Big	3403.1	8	4	1	pc	€ 5.460,00

It can be combined with Autocleaner (page 30)



# Main features

## Touch Screen user interface

A real computer that manages all the control unit's functions: adjustment of suction power, energy saving, operating parameters and maintenance alerts.

With the possibility of connecting the control unit to a remote PC, present on the same network, to remotely monitor the control unit (Master Control system, optional, see page 55)

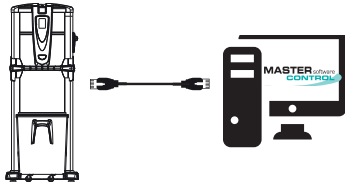

## Soft Touch container release mechanism

You don't need your strength, just Sistem Air's. We have developed a dust container release mechanism that guarantees solidity and a perfect hold without requiring any effort to release and hook the container.



## Limitless modular system

The possibility of combining several motors to a single separator gives the system extraordinary flexibility of use, making it suitable for use, with numerous advantages, in different situations:

- surfaces of several thousand square metres
- suction of solids and liquids other than dust
- possibility of total and partial selective collection of sucked materials



# Tecnical data

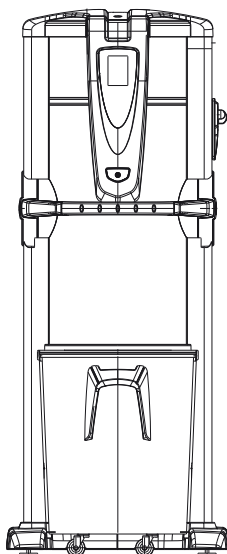

Model		Industrial Clean Small	Industrial Clean Big
		3403.0	3403.1
Article		3403.0	3403.1
Motor management computer		YES	YES
Mechanical breaker valve		YES	YES
Power supply	V ac	220/240	220/240
Frequency	Hz	50/60	50/60
Dust container capacity	l	80	106
Weight	kg	53	67
Width	mm	615	750
Height	mm	1515	1616
Depth	mm	745	745
Measure M (air input)	mm	80	100
Measure N (air output)	mm	80	100

# Basic Separators

Field of application:

industrial

hotels, industries, museums,  
cinemas, shopping centres



Max. surface to be cleaned: **unlimited**

Up to 8 users



Pipe network Ø 60 - Ø 80 - Ø 100 mm



The dust separators of the Basic line are designed as basic filtration units, without any kind of electronic control either on the connected motors or on the operating vacuum of the system.

This is a product dedicated to special applications, where there is a suction unit with separate power regulation.

PN: it is not possible to install the Autocleaner self-cleaning system on the Basic line separators.

## FEATURES

- Metal cylindrical frame painted with epoxy powder
- Case coated with anti-shock material to protect the vacuum unit
- Metal dust container from 40/80/106 l
- Bag tightener
- Safety vacuum breaker valve
- Class M certified filter
- Filter protection flange
- Reversible system connection Rt/Lh

**Basic**



Learn more about  
Industrial Clean Basic

Model	Article	Inlets IN/OUT Ø mm	Pkg	UM	Price
Wall separator LT40	3400.40	60	1	pc	€ 1.700,00
Basic separator LT80	3400.20	80	1	pc	€ 2.700,00
Basic separator LT160	3400.21	100	1	pc	€ 3.500,00

# Main features

## Soft Touch container release mechanism

On the two separators with the larger capacity dust container, you don't need your strength, just Sistem Air's. We have developed a dust container release mechanism that guarantees solidity and a perfect hold without requiring any effort to release and hook the container.



## Filter protection flange

A steel flange is attached to the body of the central vacuum cleaner to protect the filter. This protects the filter cartridge from becoming worn out even when sucking in large amounts of dust or in the presence of abrasive residue.



## Modular system

Industrial plants have no limits: the system is modular and can be adapted to any specific situation.

## Possibility of combination with Turbix

Designed as basic filtration elements, all separators in the Basic line can be combined with an appropriately sized Turbix cyclonic pre-separator to minimise filter maintenance of the separator, resulting in a basic but highly effective filtration unit.



# Tecnical data

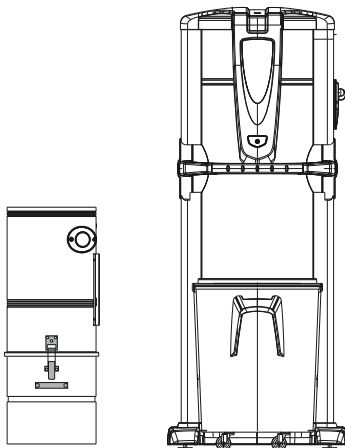

Model		Wall separator LT40	Basic LT 80	Basic LT160
Article		3400.40	3400.20	3400.21
Motor management computer		NO	NO	NO
Filter protection grid		YES	YES	YES
Safety vacuum breaker valve		NO	YES	YES
Bag tightener		YES	YES	YES
Filtering surface	cm <sup>2</sup>	19600	24000	43400
Dust container capacity	l	40	80	106
Air input	mm	60	80	100
Air output	mm	60	80	100
Weight	kg	18	53	67
Width	mm	390	615	750
Height	mm	1055	1515	1616
Depth	mm	390	745	745

# Industrial Motor Matic Motors

Field of application:

industrial

hotels, industries, museums,  
cinemas, shopping centres



Max. surface to be cleaned: **unlimited**

Up to 6 users



Pipe network Ø 63/80/100 mm



IP20



matic

With  
inverter



The motors of the **Industrial Motor Matic** line offer extraordinary vacuum power in all conditions of use. **The presence of the inverter allows modulation both to adapt to different situations and to limit power consumption.** The thermal probe is an additional safety feature, in addition to the electronic ones, to guarantee motor reliability.

## FEATURES

- Metal frame painted with epoxy powder
- Side-channel motor-pump group with light, high-performance and maintenance-free
- Electronic speed converter
- Thermal magnetic circuit breakers
- Multiple motor installations, with several motors connected to each other

**Industrial Motor**  
U4-matic



Learn more about  
Industrial Motor

Model	Article	Maximum numbers of users with flexible hose Ø 32	Pkg	UM	Price
Industrial Motor Matic 2,2 kW	<b>3503.2M</b>	1	1	pc	€ 7.000,00
Industrial Motor Matic 4 kW	<b>3513.4M</b>	2	1	pc	€ 8.600,00
Industrial Motor Matic 5,5 kW	<b>3503.6M</b>	3	1	pc	€ 10.700,00
Industrial Motor Matic 7,5 kW	<b>3503.7M</b>	4	1	pc	€ 13.250,00
Industrial Motor Matic 11 kW	<b>3503.11M</b>	6	1	pc	€ 15.700,00

# Main features

## Integrated silencers

In the side intake and exhaust ducts of blower engines, there are silencers that reduce the noise caused by the turbulence of the passing air. Additional silencers can be added to further reduce motor noise.



## Electronic speed converter

The inverter on the Matic motors, intelligently controlled by the dust separator, is guided by specific programming developed by Sistem Air, which allows the best possible vacuum performance to be achieved, avoiding critical working conditions and the potential risk of damage to electronic components.



## Easy connection

A simple serial cable is all that is needed to connect the different motors and the dust separator together: through it, all the information needed to recognise the motors and control them optimally will reach the computer board on the dust separator.



# Tecnical data

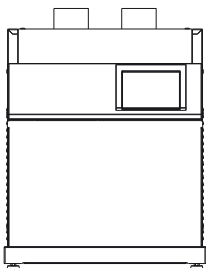

Model		Ind. Motor Matic 2,2 kW	Ind. Motor Matic 4 kW	Ind. Motor Matic 5,5 kW	Ind. Motor Matic 7,5 kW	Ind. Motor Matic 11 kW
		3503.2M	3513.4M	3503.6M	3503.7M	3503.11M
Electronic speed converter		YES	YES	YES	YES	YES
Power supply	fasi / V ac	3/400	3/400	3/400	3/400	3/400
Frequency	Hz	50/60	50/60	50/60	50/60	50/60
Motor power	kW	2,2	4	5,5	7,5	11
Inlet valves power supply	V dc	12	12	12	12	12
Maximum air flow	m³/h	366	570	740	914	1300
Air vent		YES	YES	YES	YES	YES
Weight kg		68	89	120	125	150
Width	mm	540	595	595	595	595
Height	mm	505	765	760	760	765
Depth	mm	660	812	812	812	812
Noise level lower than	dB(A)	60 ÷ 80				

**P.N:** Rated noise values may vary depending on the environment in which the control unit is installed and the type of installation

# Industrial motor Motors

Field of application:

industrial

hotels, industries, museums,  
cinemas shopping centres



Max. surface to be cleaned: **unlimited**

Up to 3 users



Pipe network Ø 80 mm



IP20



The motors in the Industrial Motor line do not have an inverter, so it is not possible to modulate the suction force. They are used in combination with Industrial Clean Basic separators to obtain basic suction units without electronic control, **suited for working in adverse environmental conditions or where modulation of the suction force is not required.**

### FEATURES

- Metal frame painted with epoxy powder
- Side-channel motor-pump group with light, high-performance and maintenance-free
- Thermal magnetic circuit breakers
- Multiple motor installations, with several motors connected to each other

Industrial Motor



Learn more about  
Industrial Motor

Model	Article	Maximum numbers of users with flexible hose Ø 32	Pkg	UM	Price
Industrial Motor 4 kW	3500.3M	2	1	pc	€ 6.950,00
Industrial Motor 5,5 kW	3500.5M	3	1	pc	€ 9.000,00

# Main features

## Integrated silencers

In the side intake and exhaust ducts of blower engines, there are silencers that reduce the noise caused by the turbulence of the passing air. Additional silencers can be added to further reduce motor noise.



## Thermal-magnetic protection

All motors have a thermal-magnetic circuit breaker integrated in the control panel.

The presence of the micro line cut-off switch provides additional protection on the motor's electrical system and makes it easier to detect any faults.



## Possibility of multiple installations

By connecting these motors to a suitable control panel, it is possible to use several suction units connected to a single separator (Basic type) in order to still have a variable suction power.



# Tecnical data

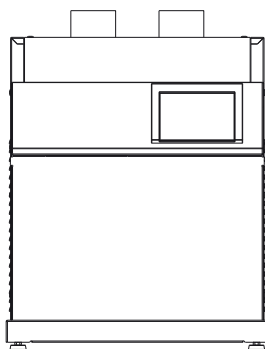

Model	4 kW		5,5 kW	
	3500.3M		3500.5M	
Article				
Electronic speed converter	NO		NO	
Power supply	fasi / V ac	3/400	3/400	
Frequency	Hz	50/60	50/60	
Motor power	kW	4	5,5	
Absorption	A	8,1	11,1	
Inlet valves power supply	V dc	12	12	
Maximum air flow	m <sup>3</sup> /h	414	536	
Air vent		YES	YES	
Weight kg		79	110	
Width	mm	540	595	
Height	mm	560	765	
Depth	mm	685	812	
Noise level lower than	dB(A)	60 ÷ 80		

**P.N:** Rated noise values may vary depending on the environment in which the control unit is installed and the type of installation

# Autocleaner Maxicleaner Self-cleaning system

Field of application:

professional industrial  
hotels, industries, museums,  
cinemas shopping centres



IP40



IP20



Thanks to a flow of compressed air through the filter in the opposite direction to the suction, the dust will be detached from its walls and fall into the dust container.

Available in two models, they can be installed at the same time as the central vacuum cleaner or can be added later on (see technical data).

## FEATURES

- Self-supporting epoxy powder-coated metal body
- Thermoformed protective coating (Autocleaner)
- Integrated compressed air tanks
- Safety valve
- Activation solenoid valve
- Multipolar connector
- Integrated compressor (only for Autocleaner)
- Supplied complete with camera body mounting bracket

MAXI  
CLEANER

**Autocleaner**  
universal system



Learn more about  
Autocleaner

Model	Article	Pkg	UM	Price
<b>Maxicleaner</b> applicable on: - Revo Block Professional - Dust separators Industrial Clean Line	<b>3600.2U</b>	1	pc	<b>€ 2.970,00</b>
<b>Autocleaner</b> applicable on: - Tecno Star Dual Power - Revo Block Professional - Dust separators Industrial Clean Line	<b>3600.0U</b>	1	pc	<b>€ 2.970,00</b>



# Main features

## Automatic and fully programmable

Once the self-cleaning system is installed, simply activate it via the display of the central vacuum cleaner or dust separator to configure

- the number of cycles of the system;
- the definition of the operating time bands, according to the customisations requested by the user (e.g. exclusion of night hours);



## Automatic filter cleaning: two solutions

Sistem Air's professional line has two types of automatic filter cleaning systems, to be chosen according to installation requirements.

**Maxicleaner:** in the case of particularly fine dust or dust vacuumed in large quantities, this is the ideal accessory for self-cleaning the filter. It does not have an integrated compressor, but must be connected to a compressed air supply line in the building. In this way, high pressures can be achieved which, combined with the large capacity of the pressure air storage tank, always allow the filter surface to be freed of dirt.

**Autocleaner** does not need to be connected to external self-cleaning sources. It has everything needed to effectively clean the filter in the case of dust that is not extremely fine or such that it does not compact on the filter walls.



# Tecnical data

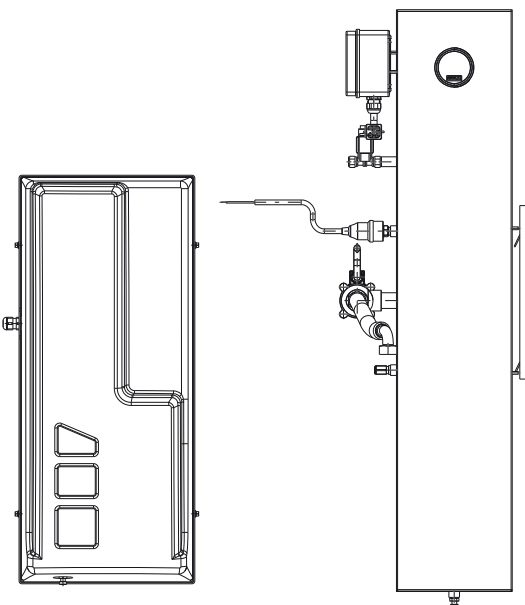

MODEL	ARTICLE	Maxicleaner	Autocleaner
		3600.2U	3600.0U
Air input	Ø"	3/8 G	-
Air output	Ø"	3/4"	3/4"
Protection class	IP		40
Power supply	V ac	220/240	220/240
Frequency	Hz	50	50/60
Power	W	-	250
Absorption	A	-	1,3
Air pressure	bar	3,5	3,5
Tank capacity	l	37	6
Height	mm	1035	730
Width	mm	253	328
Depth	mm	300	220

Turbix

# Turbix

## Cyclonic separators

Field of application:

domestic and professional

workshops, industries, museums, cinemas



Pipe network Ø 50 - 63 - 80 - 100 mm



Turbix are cyclonic pre-separators useful for intercepting more than 98% of sucked dust and preserving the filter, reducing maintenance cycles and maintaining the performance of the central vacuum cleaner.

### FEATURES

- Metal body and base epoxy powder-coated
- Dust container:
  - Turbix Small** 21 l polypropylene with handles
  - Turbix Medium** 40 l metal with handles
  - Turbix Big** 70 l metal with wheels
  - Turbix Big XL** 106 l metal with wheels
- Reversible system connection Rt/Lh



Learn more about Turbix

Model	Article	Inlets IN/OUT Ø mm	Pkg	UM	Price
Turbix Small Ø 50 mm	3400.10	50	1	pc	€ 670,00
Turbix Medium Ø 60 mm	3400.11	60	1	pc	€ 850,00
Turbix Big Ø 80 mm	3400.12	80	1	pc	€ 2.550,00
Turbix Big XL Ø 100 mm	3400.13	100	1	pc	€ 3.700,00

# Main features

## Cyclonic separation

The filtration of the air from the suctioned dust takes place by cyclonic separation. The shape of the cone gives the suctioned dust a cyclonic motion with increasing speed. At the end of the cone, the air slows down and allows the dust to fall into the Turbix dust container without fouling the central vacuum cleaner filter.

A guarantee of effectiveness but, above all, a simplification in maintenance. Turbix contains no filter cartridge.

## Great effectiveness

With Turbix, suction has no limits. you can remove any type of material, even the finest and dustiest, such as:

- Animal hair
- Flours
- Hair
- Soil
- Metal shavings
- Plastic granulates
- Grinding dusts
- Sawdust

## Soft Touch container release

On both the smaller separators (Small and Medium for wall mounting) and the larger ones (Big and Big XL), we have developed a dust-container release mechanism that guarantees solidity and a perfect hold without requiring any effort to release and hook the dust container.

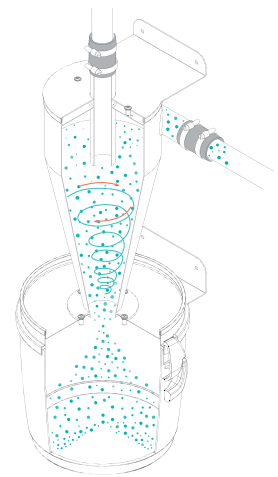

# Tecnical data

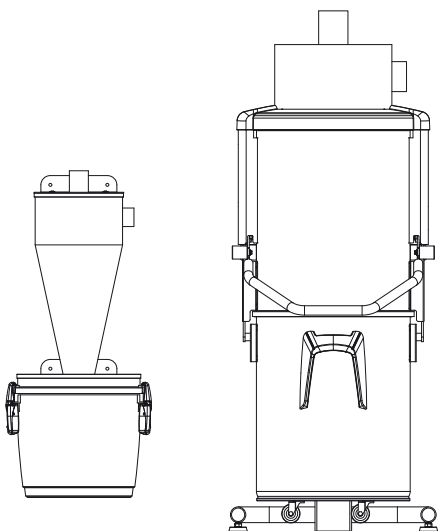

Model		Turbix Small	Turbix Medium	Turbix Big	Turbix Big XL
Article		3400.10	3400.11	3400.12	3400.13
Dust input/output	∅ mm	50	60	80	100
Dust container capacity	l	21	40	70	106
Weight	kg	15	25	53	70
Width	mm	385	452	552	680
Depth	mm	360	436	590	700
Height	mm	855	1105	1395	1600
Minimum height from ground	mm	100	100	-	-

# Auto Jet Turbix Separator

Field of application:

industrial  
industries, laboratories



Pipe network Ø 80 mm

Output opening Ø 153 mm



IP44



The special Auto Jet Turbix separator is designed for use in all applications where the capacity of the collection container is not sufficient to hold all the material sucked during a work cycle. The automatic opening system of the collection container door allows the contents to be discharged in a customised manner, thus avoiding frequent machine downtimes. The presence of the cyclonic cone allows effective dedusting of the sucked air, thus prolonging the efficiency of the filter in the central vacuum cleaner.

## FEATURES

- Cyclonic separation without filter
- Made of stainless steel
- Reversible pipe connections
- Easy to install and use

**AUTO Jet** TURBIX



Learn more about  
Auto Jet

Model	Article	Inlets IN/OUT Ø mm	Discharge Ø mm	Pkg	UM	Price
Auto Jet Turbix	7010.3	80	153	1	pc	€ 7.850,00

# Main features

## Guaranteed opening

The lower door is operated by a robust pneumatic actuator, which allows it to be opened under all loading conditions, so that the material in the collection container can always be unloaded.



## Easy unloading by means of 8 air jets

To facilitate the discharge of all types of sucked material, even the lightest and bulkiest, the separator is equipped with 8 nozzles that trigger a jet of compressed air when the discharge flap is opened.



## Easy to programme

Thanks to the three potentiometers on the control panel, the following operating parameters can be adjusted:

1. suction time (to prevent overfilling of the container);
2. door opening time (to be set according to the specific weight and consistency of the material sucked in);
3. repetition of compressed air jets acting during discharge.

Using the TEST button it is possible to test each of these three settings immediately in order to find the optimal setting according to the quantity and type of material sucked.



# Tecnical data

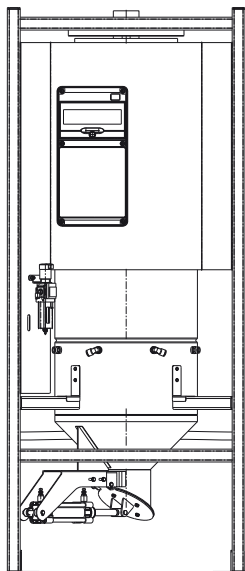

Model	Auto Jet Turbix	
Article	7010.3	
Vacuum management board		YES
Protection class	IP	44
Power supply	V ac	230
Absorption	A	1,5
Container capacity	l	76
Pneumatic actuator pressure	bar	6
Air input	G	3/4
Nozzle pressure		*
Weight	kg	105
Width	mm	740
Height	mm	1760
Depth	mm	740

\*Same maximum operating pressure as system

# Roll Flex

## Motorised hose reel

Field of application:

industrial  
wide open spaces



Pipe network Ø 50 mm



IP40



Roll Flex is the motorised hose reel designed by Sistem Air to simplify the use of the centralised vacuum system in all those situations where it is necessary to cover a large area with a single hose, reducing plant complexity and possible floor space requirements. The robust gearmotor mechanism makes it particularly suitable for use in professional and industrial environments.

### FEATURES

- Roll Flex is equipped with a motorised unwinding/rewinding system, characterised by extreme robustness, thanks to the use of professional mechanical and electrical components
- Simple to use: two microswitches control the direction of rotation of the winder. Starting and stopping the suction are automatic
- Ceiling-mounted (or wall-mounted with optional bracket)

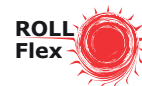

Learn more about Roll Flex

Model	Article	Hose supplied Ø mm	Pkg	UM	Price
Roll Flex Ø 32	7041.51E	35	1	pc	€ 1.910,00
Roll Flex Ø 40	7041.61E	40	1	pc	€ 2.150,00

# Main features

## Customisable controls

The control panel supplied as standard can be extended or replaced with other devices for remote control also via radio, introducing, for example, timings on vacuum cleaner operation. This allows maximum adaptation of the system to the needs of each specific application.



## Sturdy and safe

The unwinding/rewinding mechanism is of a professional type, capable of performing several work cycles without any problems. At the same time it is equipped with safety devices to prevent accidental lifting of large objects.



# Technical data

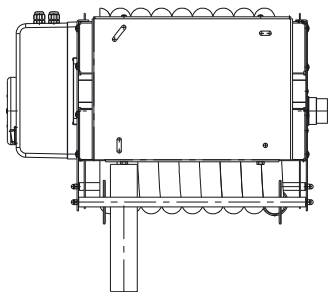

Model		Roll Flex	Roll Flex
		Ø 32	Ø 40
Article		7041.51E	7041.61E
Protection class	IP	40	40
Power supply	V ac	220/240	220/240
Frequency	Hz	50/60	50/60
Motor power	W	120*	120*
Absorption	A	0,92*	0,92*
Number of laps	RPM	26*	26*
Weight	Kg	36	38
Inlet connection (D)	Ø mm	50	50
Hose supplied	Ø mm	35	40
Maximum hose length	m	18	20
Width	mm	660	660
Height	mm	480	480
Depth	mm	425	425

# Reel accessories

## Curved connector



Article	Material	Pkg	U.m.	Price
● 7039.5	Plastic	1	pc	€ 35,00
Only for Roll Flex Ø 32				

## Metal plate

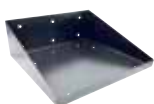

Article	Material	Pkg	U.m.	Price
● 7041.100	Steel	1	pc	€ 165,00
To fix the Roll Flex to the wall				

# Industrial complements

Field of application:

industrial

hotels, industries, museums, cinemas shopping centres



For professional and industrial installations



Complements for industrial vacuum system are system components that allow customisation and correct operation of professional central vacuum cleaners and/or modular systems. The choice of suitable accessories allows, by combining standard products, to arrive at sophisticated systems capable of integrating with the most varied production processes and allowing the suction unit to operate for many hours, even in continuous operation.



Learn more



## Air vent silencers



Article	Description	Pkg	U.m.	Price
● 11001	Metal vent silencer 2"	1	pc	€ 190,00
● 11002	Metal vent silencer 3"	1	pc	€ 260,00
● 11003	Metal vent silencer 4"	1	pc	€ 340,00

## Check valves for motor matching



Article	Description	Pkg	U.m.	Price
● 0110001	Check valves 2" motor matching	1	pc	€ 150,00
● 0110002	Check valves 4" motor matching	1	pc	€ 380,00
● 0110003	Check valves 3" motor matching	1	pc	€ 270,00

## Automation and control elements



Article	Description	Pkg	U.m.	Price
○ 3301.0	Electric panel starting system 3 motors*	1	pc	€ 1.590,00
○ 3301.6	Electric panel starting system 2 motors*	1	pc	€ 1.530,00

\*for electric motors only



○ 3301.20	Automatic control panel industrial touch system	1	pc	€ 3.080,00
-----------	---	---	----	------------



● 3301.4	Resistive divider with 4 entries*	1	pc	€ 32,00
----------	-----------------------------------	---	----	---------

\*for electric motors only

## Vacuum breaker valves



Article	Description	Pkg	U.m.	Price
● 2050.5	Vacuum breaker valves Ø 80	1	pc	€ 100,00
● 2050.7	Vacuum breaker valves Ø 100	1	pc	€ 120,00

## Steel exhaust Kit



Article	Description	Pkg	U.m.	Price
○ 7020.63	Steel exhaust Kit Ø 60	1	pc	€ 210,00
○ 7020.80	Steel exhaust Kit Ø 80	1	pc	€ 320,00
○ 7020.10	Steel exhaust Kit Ø 100	1	pc	€ 435,00

## Pneumatic sleeve valves



Article	Description	Pkg	U.m.	Price
● 1456.5MA	Pneumatic sleeve valves Ø 50 230 V ac	1	pc	€ 810,00
● 1456.4MA	Pneumatic sleeve valves Ø 60 230 V ac	1	pc	€ 1.040,00
● 1456.6MA	Pneumatic sleeve valves Ø 80 230 V ac	1	pc	€ 1.520,00

# Inlet Valves

Field of application:

domestic  
professional  
industrial

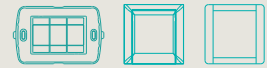

Pipe network Ø 50 mm



Inlet valves connect the pipe network of the central vacuum system and the hose used for cleaning.

They are an **essential element** to guarantee the tightness of the system and **maintain the vacuum within the pipe network**.

All inlet valves are **compatible with standard hoses and Flisy and Flisy 2 wireless hoses**.

## Flisy 2 wireless on/off cleaning hoses



The system starts when the hose is inserted into the vacuum valve.

The button on the handle can then be used to **switch the vacuum on and off** as required.



## Standard cleaning hoses

The suction system is switched on when the hose is inserted into the inlet valve.

To switch off the system, simply pull out the hose, interrupting suction.



# Main features

Available in rectangular (Virtus or Generation), square (Standard or Design) or professional versions, Sistem Air's valves represent the best line on the market.

## Different uses, different aspects

- **Domestic:** design, watertightness and stability of the aesthetic plate are basic requirements for valves for domestic applications.
- **Professional:** robustness, adaptability to the environment and watertightness are required in industrial applications.

## What makes Virtus valves unique

Innovations designed by Sistem Air take the experience of using a central vacuum system to a higher level, guaranteed over time.

- 1- Double o-ring seat for a perfect seal
- 2- Frame structure identical to that of the chosen civil series
- 3- Beautiful and practical, the caps blend in with the aesthetics of the room
- 4- Mechanical resistance thanks to rounded walls and ribs
- 5- Reinforced supporting structure that increases torsional rigidity
- 6- SEBS gasket, prevents memory effect and remains unaltered over time
- 7- Ultra-fast connection using wiring terminals
- 8- Works with all hoses on the market

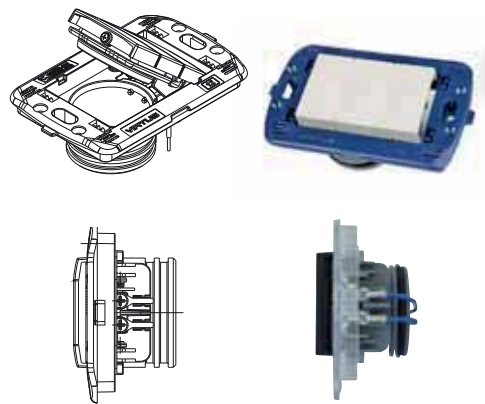

## Available for the main civil series on the market

The Sistem Air inlet valves mirror the respective domestic series in every detail, not only in the shape of the switches but also in the colours and finish. A perfect resemblance that makes it possible to combine electrical switches and inlet valves.

Sistem Air inlet valves are fitted with the original finish plates of the following brands:



## Design for all tastes

The interchangeable covers are available in a palette of 12 colours, in Dark, Natural and Fruit variants, for maximum aesthetic expression of the room.



## Durable and safe in professional applications

Even in the industrial field, Sistem Air valves represent excellence, thanks to their robustness and the availability of antistatic or ATEX-certified versions, which allow them to be used even in explosion-hazardous environments.



# Rectangular inlet valves

**VIRTUS**

## BTicino inlet valves

### BTicino Living Light inlet valve



Article	Description	Pkg	U.m.	Price
● 1561.0	Black	10	pcs	€ 48,00
○ 1562.0	White	10	pcs	€ 48,00
● 1565.0	Tech	10	pcs	€ 52,00

### BTicino Air inlet valve



Article	Description	Pkg	U.m.	Price
● 1570.0	Anthracite	10	pcs	€ 48,00
○ 1571.0	White	10	pcs	€ 48,00
● 1572.0	Tech	10	pcs	€ 52,00

### BTicino Axolute Air inlet valve



Article	Description	Pkg	U.m.	Price
● 1573.1	Black	10	pcs	€ 52,00
○ 1573.2	White	10	pcs	€ 52,00
● 1573.3	Tech	10	pcs	€ 52,00

### BTicino Luna inlet valve



Article	Description	Pkg	U.m.	Price
○ 1568.0	White*	10	pcs	€ 48,00

\*series Generation

### BTicino Now inlet valve



Article	Description	Pkg	U.m.	Price
● 1573.5	Black	10	pcs	€ 48,00
○ 1573.4	White	10	pcs	€ 48,00
● 1573.6	Sand	10	pcs	€ 48,00

### BTicino Axolute inlet valve



Article	Description	Pkg	U.m.	Price
● 1566.0	Black	10	pcs	€ 52,00
○ 1564.0	White	10	pcs	€ 52,00
● 1567.0	Tech	10	pcs	€ 52,00

### BTicino Matic inlet valve



Article	Description	Pkg	U.m.	Price
○ 1569.0	White	10	pcs	€ 48,00

## Vimar inlet valves

### Vimar Eikon Evo inlet valve



Article	Description	Pkg	U.m.	Price
● 1558.0	Black	10	pcs	€ 48,00
○ 1558.1	White	10	pcs	€ 48,00
● 1553.5	Next	10	pcs	€ 52,00

### Vimar Idea inlet valve



Article	Description	Pkg	U.m.	Price
● 1553.0	Black	10	pcs	€ 48,00
○ 1553.2	White	10	pcs	€ 48,00

### Vimar Arkè Fit inlet valve



Article	Description	Pkg	U.m.	Price
● 1553.12	Anthracite	10	pcs	€ 48,00
○ 1553.13	White	10	pcs	€ 48,00
● 1553.14	Metal	10	pcs	€ 52,00

### Vimar Arkè inlet valve



Article	Description	Pkg	U.m.	Price
● 1553.9	Anthracite	10	pcs	€ 48,00
○ 1553.10	White	10	pcs	€ 48,00
● 1553.11	Metal	10	pcs	€ 52,00

### Vimar Plana inlet valve



Article	Description	Pkg	U.m.	Price
○ 1553.4	White	10	pcs	€ 48,00
● 1553.3	Silver	10	pcs	€ 52,00

### Vimar Linea inlet valve



Article	Description	Pkg	U.m.	Price
○ 1553.15	White	10	pcs	€ 4800
● 1553.16	Hemp	10	pcs	€ 48,00
● 1553.17	Black	10	pcs	€ 48,00

## Simon Urmet inlet valves

### Simon Urmet Nea inlet valve



Article	Description	Pkg	U.m.	Price
● 1543.0	Anthracite	10	pcs	€ 48,00
○ 1543.1	White	10	pcs	€ 48,00
● 1543.2	Dark steel	10	pcs	€ 52,00
○ 1543.3	Ice white	10	pcs	€ 52,00
● 1543.4	Steel	10	pcs	€ 52,00

## Rectangular inlet valves

*Generation*

### Ave inlet valves

#### Ave Allumia S44 Inlet valve



Article	Description	Pkg	U.m.	Price
● 1563.7	Titanium	1	pc	€ 66,00

#### Ave Blanc Inlet valve



Article	Description	Pkg	U.m.	Price
○ 1563.0	White	1	pc	€ 48,00

#### Ave Life 44 Inlet valve



Article	Description	Pkg	U.m.	Price
● 1563.5	Black	1	pc	€ 66,00

#### Ave Tekla Inlet valve



Article	Description	Pkg	U.m.	Price
● 1563.9	Matt black	1	pc	€ 66,00

#### Ave Banquise Inlet valve



Article	Description	Pkg	U.m.	Price
○ 1563.2	White	1	pc	€ 48,00

#### Ave Domus 100 Inlet valve



Article	Description	Pkg	U.m.	Price
○ 1563.6	White	1	pc	€ 66,00

#### Ave Noir Inlet valve



Article	Description	Pkg	U.m.	Price
● 1562.0	Black	1	pc	€ 48,00

#### Ave Touch Inlet valve



Article	Description	Pkg	U.m.	Price
● 1563.3	Black	1	pc	€ 130,00
○ 1563.4	White	1	pc	€ 140,00
● 1563.8	Allumia	1	pc	€ 150,00

## Gewiss inlet valves

### Gewiss Chorus Inlet valve



Article	Description	Pkg	U.m.	Price
● 1557.2	Black	20	pcs	€ 48,00
○ 1557.1	White	20	pcs	€ 48,00
○ 1557.3	Titanium	20	pcs	€ 48,00

### Gewiss Playbus Inlet valve



Article	Description	Pkg	U.m.	Price
● 1557.0	Black	20	pcs	€ 48,00

## Abb inlet valves

### Abb Chiara Inlet valve



Article	Description	Pkg	U.m.	Price
○ 1542.0	White	1	pc	€ 48,00

### Abb Mylos Inlet valve



Article	Description	Pkg	U.m.	Price
● 1542.1	Black	1	pc	€ 66,00
○ 1542.2	White	1	pc	€ 66,00

### Abb Élos Inlet valve



Article	Description	Pkg	U.m.	Price
● 1541.0	Black	1	pc	€ 48,00

## Legrand inlet valves

### Legrand Vela Inlet valve



Article	Description	Pkg	U.m.	Price
● 1551.4	Black	1	pc	€ 48,00
○ 1551.3	White	1	pc	€ 48,00

## Square inlet valves

STANDARD

### Square Inlet valves



Article	Description	Pkg	U.m.	Price
○ 1464.0B	White	1	pc	€ 40,00
● 1464.1B	Ivory	1	pc	€ 40,00
● 1464.2B	Silver	1	pc	€ 49,00

## Square inlet valves

DESIGN

### Design Inlet valves



Article	Description	Pkg	U.m.	Price
○ 1467.0	White	1	pc	€ 42,50



Article	Description	Pkg	U.m.	Price
● 1468.0	Complete inlet body	1	pc	€ 38,00

### Interchangeable covers by Design

#### Natural tones Cover set



Article	Description	Pkg	U.m.	Price
○ 1467.C2	Creme	1	pc	€ 7,00
○ 1467.C8	Light gray	1	pc	€ 7,00
● 1467.C6	Sand	1	pc	€ 7,00
○ 1467.C9	Vanille	1	pc	€ 7,00

#### Dark tones Cover set



Article	Description	Pkg	U.m.	Price
● 1467.C1	Dark gray	1	pc	€ 7,00
● 1467.C5	Black	1	pc	€ 7,00
● 1467.C4	Silver	1	pc	€ 13,00
● 1467.C10	Coffee	1	pc	€ 7,00

#### Fruit tones Cover set



Article	Description	Pkg	U.m.	Price
● 1467.C3	Lemon	1	pc	€ 7,00
● 1467.C11	Berry	1	pc	€ 7,00
● 1467.C7	Olive	1	pc	€ 7,00



# Special inlet valves

## Vacpan inlet valve



Article	Description	Pkg	U.m.	Price
○ 1464.2	White	1	pc	€ 103,00
● 1464.3	Black	1	pc	€ 103,00
● 1464.5	Silver	1	pc	€ 112,00

## Infloor inlet valve



Article	Description	Pkg	U.m.	Price
● 1455.0A	Gray Ø 32	1	pc	€ 125,00
● 1455.0N	Black Ø 32	1	pc	€ 125,00
● 1455.2A	Gray Ø 40	1	pc	€ 133,00
● 1455.2N	Black Ø 40	1	pc	€ 133,00

## Steel key for infloor inlet valve



Article	Description	Pkg	U.m.	Price
● 1400.1	Steel	1	pc	€ 5,60

## External inlet valve



Article	Description	Pkg	U.m.	Price
○ 1459.5	White	1	pc	€ 72,00

# Industrial inlet valves with microswitch

## Industrial inlet valves with microswitch



Article	Description	Pkg	U.m.	Price
● 1556.0	Black Ø 32/40	1	pc	€ 95,00



Article	Description	Pkg	U.m.	Price
● 1556.0A	Industrial antistatic valve c/micro Ø 32/40	1	pc	€ 128,00
● 1556.0AX	Industrial antistatic valve c/micro ATEX Ø 32/40*	1	pc	€ 307,00

\*Atex zone 22 certified microswitch valve

# Motorised hose reel



Article	Description	Pkg	U.m.	Price
● 7041.51E	Roll Flex Ø 32 mm	1	pc	€ 1.910,00
● 7041.61E	Roll Flex Ø 40 mm	1	pc	€ 2.150,00

# PVC

## Installation material

Field of application:

domestic  
professional  
industrial



Pipe network:

2"  
Ø 50 mm  
Ø 63 mm  
Ø 80 mm  
Ø 100 mm



The Sistem Air installation material is designed to ensure a perfect fit between the pipework and fittings.

In particular, the pipes are **antistatic, self-extinguishing and calibrated** in thicknesses between 2.2 mm and 3 mm.

The jointing is carried out by gluing with a special **cold self-welding** glue that guarantees a perfect seal of the glued components.

The absence of sharp 90° turns facilitates the passage of air and any aspirated bodies, so that the risk of obstruction is eliminated and the suction power remains intact.

### FEATURES

- Antistatic pipes
- Self-extinguishable
- Calibrate
- With thicknesses between 2.2 mm and 3 mm



Installation  
Guide

# Main features

## Calibrated fittings, maximum efficiency

Sistem Air's installation material is designed to maintain the same internal diameter at all times to avoid inefficiencies and pressure drops when air and suction dust pass through.

The high thickness ensures its resistance to the stresses that may be encountered on site. Striking notches and arrows indicating air direction further simplify installation.



## Backplates without surprises

Our backplates are suitable for installation on both masonry and plasterboard walls. They have a connector that can rotate through 270°, and have numerous pre-marked holes so that the electrical connections of the microswitch line can be made with ease.

Furthermore, on the mortar door, in the rectangular version, there is a marker that allows, with the help of a common metal detector, to precisely trace them under the plaster in case they have been covered by mistake.

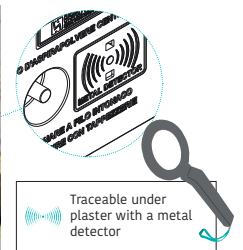

## To each his own diameter

All PVC installation material is available in diameters 50/63/80/100 mm, with the appropriate adapters to switch from one size to another, so that in multi-user plants, each pipe section can be made with the appropriate diameter to allow for a flow of air capable of satisfying the intended simultaneous use requirement.



## Special situations

There are situations in which it is necessary to adopt dedicated installation solutions in order to ensure that the piping network is properly constructed and sealed throughout its development.



## Criteria for the selection of pipework

PVC pipe and fittings are suitable for all types of central vacuum system installations. Where there are particular problems with mechanical resistance or in the case of exposed pipe installations, antistatic steel pipes can be used.

## Notes

When it is necessary to cross an external section with rigid pipework, appropriate insulation and the use of expansion joints should be provided. Different materials compromise the guarantee of the system and can create blockages in the pipe network.

## Warnings

The installation material is specially made for centralised vacuum cleaning. Using the dedicated plant material allows you to realise installations with the highest performance guarantee.

## Installation kits for standard system

They include the material for setting up a central vacuum system. The kits can be added together in order to obtain the desired inlet points.

By using the kits, in buildings with a regular layout, you are sure to have all the material to complete the pipework.

### Installation kits with rectangular backplates



FOR THE INSTALLATION OF INLET VALVES SERIES



- Virtus
- Generation

Article	Description	Pkg	U.m.	Price
7030.3	Installation kit for 3 rectangular backplates	1	pc	€ 307,00
7030.4	Installation kit for 4 rectangular backplates	1	pc	€ 420,00
7030.5	Installation kit for 5 rectangular backplates	1	pc	€ 530,00

Art.	Inlets point	Backplates curved fitting	PVC pipe	Elbow MF	Elbow FF	Wye FF	Sleeve	Venting grid	Pre-wired cable	Glue 250 gr
7030.3	3	3 pcs	20 m	9 pcs	12 pcs	3 pcs	9 pcs	1 pcs	25 m	1 pcs
7030.4	4	4 pcs	28 m	12 pcs	16 pcs	4 pcs	12 pcs	1 pcs	37,5 m	1 pcs
7030.5	5	5 pcs	36 m	15 pcs	20 pcs	5 pcs	15 pcs	1 pcs	50 m	1 pcs

### Installation kits with square backplates



FOR THE INSTALLATION OF INLET VALVES SERIES



- Design
- Square Standard

Article	Description	Pkg	U.m.	Price
7030.3E	Installation kit for 3 square backplates	1	pc	€ 307,00
7030.4E	Installation kit for 4 square backplates	1	pc	€ 420,00
7030.5E	Installation kit for 5 square backplates	1	pc	€ 530,00



Art.	Inlets point	Backplates curved fitting	PVC pipe	Elbow MF	Elbow FF	Wye FF	Sleeve	Venting grid	Pre-wired cable	Glue 250 gr
7030.3E	3	3 pcs	20 m	9 pcs	12 pcs	3 pcs	9 pcs	1 pcs	25 m	1 pcs
7030.4E	4	4 pcs	28 m	12 pcs	16 pcs	4 pcs	12 pcs	1 pcs	37,5 m	1 pcs
7030.5E	5	5 pcs	36 m	15 pcs	20 pcs	5 pcs	15 pcs	1 pcs	50 m	1 pcs

# Standard system installation material

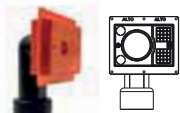
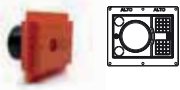

## Universal rectangular backplates

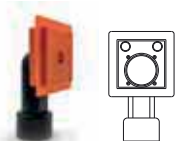
	Article	Description	Pkg	U.m.	Price
	1450.0	Rectangular with curved fitting	10	pcs	€ 15,40
	1450.1	Rectangular with straight fitting	10	pcs	€ 15,40

## Universal square backplates

	Article	Description	Pkg	U.m.	Price
	1450.4B	Square with curved fitting	10	pcs	€ 14,90
	1450.5B	Square with straight fitting	10	pcs	€ 14,90





## Floor level backplates

	Article	Description	Pkg	U.m.	Price
	1450.2	Floor-level, curved aluminium fitting	10	pcs	€ 80,00
	1450.3	Floor-level, straight aluminium fitting	10	pcs	€ 85,00
	1450.23	Floating floor adapter	10	pcs	€ 32,00

## Backplate for vacpan inlet

	Article	Description	Pkg	U.m.	Price
	1450.16	backplate for vacpan inlet	1	pc	€ 145,00

## Backplate extension kit

	Article	Description	Pkg	U.m.	Price
	1450.8	Rectangular backplate extension kit	10	pcs	€ 11,10
	1450.9	Square backplate extension kit	10	pcs	€ 11,10
	1457.1	Extension for domestic line inlet valves	10	pcs	€ 5,60
	1457.2	Extension for floor inlet valves	10	pcs	€ 48,00

## Standard system installation material

### PVC Pipes



Article	Description	Pkg	U.m.	Price
1850.0	PVC pipe Ø 50 mm thick 2,2 mm (bars m 2)	20	m	€ 5,50
1863.0	PVC pipe Ø 63 mm thick 3 mm (bars m 2)	10	m	€ 12,00
1880.0	PVC pipe Ø 80 mm thick 3 mm (bars m 2)	10	m	€ 16,00
1810.0	PVC pipe Ø 100 mm thick 3 mm (bars m 2)	10	m	€ 18,00
1850.0B	PVC pipe Ø 50 mm bars 2 m (imb. m 500)	1	pc	€ 2,750,00
1863.0B	PVC pipe Ø 63 mm bars 2 m (imb. m 300)	1	pc	€ 3,600,00

### Elbows



Elbow MF



Elbow FF

Article	Description	Pkg	U.m.	Price
3050.0	PVC elbow 45° MF Ø 50 mm	60	pcs	€ 2,70
3050.1	PVC elbow 45° FF Ø 50 mm	60	pcs	€ 2,70
3063.0	PVC elbow 45° MF Ø 63 mm	30	pcs	€ 7,50
3063.1	PVC elbow 45° FF Ø 63 mm	30	pcs	€ 7,50
3080.0	PVC elbow 45° MF Ø 80 mm	1	pc	€ 10,50
3080.1	PVC elbow 45° FF Ø 80 mm	1	pc	€ 14,00
3010.0	PVC elbow 45° MF Ø 100 mm	1	pc	€ 17,00
3010.1	PVC elbow 45° FF Ø 100 mm	1	pc	€ 19,00

### Sleeve



Article	Description	Pkg	U.m.	Price
1150.1	PVC sleeve with shutter Ø 50 mm	100	pcs	€ 1,60
1163.1	PVC sleeve with shutter Ø 63 mm	40	pcs	€ 4,60
1180.1	PVC sleeve with shutter Ø 80 mm	1	pc	€ 6,00
1110.1	PVC sleeve with shutter Ø 100 mm	1	pc	€ 8,00

### Wye



Wye MF



Wye FF

Article	Description	Pkg	U.m.	Price
4050.0	PVC wye 45° MF Ø 50 mm	20	pcs	€ 4,90
4050.1	PVC wye 45° FF Ø 50 mm	20	pcs	€ 4,90
4063.0	PVC wye 45° MF Ø 63 mm	15	pcs	€ 16,00
4063.1	PVC wye 45° FF Ø 63 mm	15	pcs	€ 16,00
4080.0	PVC wye 45° MF Ø 80 mm	1	pc	€ 18,00
4080.1	PVC wye 45° FF Ø 80 mm	1	pc	€ 20,00
4010.0	PVC wye 45° MF Ø 100 m	1	pc	€ 23,50
4010.1	PVC wye 45° FF Ø 100 mm	1	pc	€ 27,00

## Prewired cable



Article	Description	Pkg	U.m.	Price
● 9016.7	Prewired cable mt 25	1	pc	€ 60,00
9016.0	Prewired cable mt 50	1	pc	€ 110,00
9016.1	Prewired cable mt 100	1	pc	€ 208,00

## Screw plug



Article	Description	Pkg	U.m.	Price
● 5050.1	PVC screw plug Ø 50 mm	1	pc	€ 6,40
6063.1	PVC screw plug Ø 63 mm	1	pc	€ 17,00
8080.1	PVC screw plug Ø 80 mm	1	pc	€ 20,00
1010.1	PVC screw plug Ø 100 mm	1	pc	€ 21,50

## Eccentric extension



Article	Description	Pkg	U.m.	Price
● 6063.3	PVC eccentric extension Ø 50/63 mm	1	pc	€ 8,00
8080.3	PVC eccentric extension Ø 63/80 mm	1	pc	€ 11,00
1010.3	PVC eccentric extension Ø 80/100 mm	1	pc	€ 12,00

## Special glue



Article	Description	Pkg	U.m.	Price
○ 9225.1	Special glue with brush 250 gr	1	pc	€ 23,50
9225.2	Special glue with brush 500 gr	1	pc	€ 40,00

## Silencer



Article	Description	Pkg	U.m.	Price
● 110001	PVC silencer Ø 50 mm	1	pc	€ 50,00
● 110002	PVC silencer Ø 63 mm	1	pc	€ 122,00



○ 5050.4	PVC vent grid Ø 50 mm	1	pc	€ 18,00
○ 5063.4	PVC vent grid Ø 63 mm	1	pc	€ 21,00

## Expansion joint



Article	Description	Pkg	U.m.	Price
● 5050.0	PVC expansion joint Ø 50 mm	1	pc	€ 23,50
5050.2	PVC expansion joint Ø 63 mm	1	pc	€ 35,00

### Equipment



Article	Description	Pkg	U.m.	Price
● 4163.0	Pipe cutting tool for pipes up to Ø 63 mm	1	pc	€ 142,00
4100.0	Pipe cutting tool for pipes up to Ø 100 mm	1	pc	€ 340,00
● 4163.1	Spare wheel for pipe-cutting tool	1	pc	€ 18,00

### Fire stop coupling



Article	Description	Pkg	U.m.	Price
● 1150.3	Fire stop coupling Ø 50 mm	1	pc	€ 220,00
1163.2	Fire stop coupling Ø 63 mm	1	pc	€ 240,00
1180.2	Fire stop coupling Ø 80 mm	1	pc	€ 267,00
1110.2	Fire stop coupling Ø 100 mm	1	pc	€ 286,00

### Ball valve for manual section



Article	Description	Pkg	U.m.	Price
● 2050.0	PVC ball valve for manual section Ø 50 mm	1	pc	€ 122,00
2050.1	PVC ball valve for manual section Ø 63 mm	1	pc	€ 190,00
2050.2	PVC ball valve for manual section Ø 80 mm	1	pc	€ 340,00
2050.3	PVC ball valve for manual section Ø 100 mm	1	pc	€ 420,00
● 2050.0CM	Valves with micro Ø 50 mm	1	pc	€ 194,00

## Testing for standard and Sense installations

### System test



Article	Description	Pkg	U.m.	Price
● 5050.5	Test plug for domestic series installations	1	pc	€ 5,30
● 4001.0	Vuotometer	1	pc	€ 127,00
● 4300.1	System Test	1	pc	a richiesta



## Connection to the Air Cloud network

The Sistem Air wireless module is an extender that enables the internet connection via Wi-Fi of the Tecno Prime central vacuum cleaner to Air Cloud services. **It is necessary to have an active internet connection for Air Cloud to function properly and to obtain the 6-year Cloud Warranty.**

### Wi Fi module



	Article	Description	Pkg	U.m.	Price
<input type="radio"/>	4202.2	Wi-Fi for Tecno Prime central vacuum cleaner	1	pc	€ 106,00

## Remote control of professional installations

Remote Control Master Control, the innovative communication system designed by Sistem Air for remote monitoring of industrial and professional central vacuum cleaners. **For correct operation, the Master Control software and LAN card must work together.**

### Master Control system

The Master Control software enables real-time control of all central vacuum cleaners connected to the local network in the building. The perfect mechanism to make the system connected.



	Article	Description	Pkg	U.m.	Price
<input checked="" type="radio"/>	4202.0	Software Master Control Sistem air	1	pc	€ 265,00

### LAN card

The Master Control connection card is the interface that allows the information shown on the display to be transmitted over a local network, to which both the central vacuum cleaner and the PC from which remote control is to be carried out are connected.



	Article	Description	Pkg	U.m.	Price
<input type="radio"/>	4202.1	LAN card Master Control Sistem Air	1	pc	€ 550,00

# Steel

## Installation material

Field of application:  
industrial

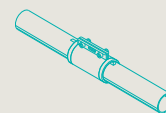

Pipe network:  
Ø 50 mm  
Ø 60 mm  
Ø 80 mm  
Ø 100 mm

**Steel installation material responds to precise requirements that emerge particularly in industrial applications**, where suction of:

1. particularly fine materials, different from common domestic dust, and capable of generating considerable static charges along the pipeline
2. materials that, due to their weight, consistency and temperature, could damage PVC pipework
3. dust and explosive gases

Sometimes the choice falls on this type of system for aesthetic reasons or for the resistance required depending on the installation context: what all these situations have in common is the robustness, electrical conductivity and perfect watertightness of the systems created.

### FEATURES

- Sturdiness
- Electrical conductivity
- Watertightness
- Antistatic material



Discover  
Sistem Air Pro



# Main features

## Sturdiness

The pipes and fittings are made of zinc coated steel, with thicknesses to ensure solidity of the assembled pipework without excessive weight in the case of anchoring to overhead structures.



## Continuity and tightness

Thanks to the special junction sleeves, the realisation of the pipes network is particularly simple: the connection between the different elements is realised by tightening the steel fittings, inside of which is a rubber sleeve that guarantees watertightness. A metal flap brings the two steel elements to be connected into contact, thus guaranteeing electrical continuity and simplifying the earthing of the entire network.

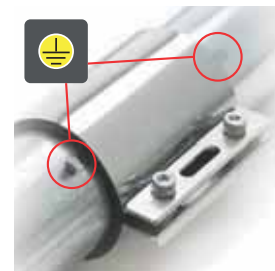

## To each his own diameter

The steel installation material is also available in diameters 50/60/80/100 mm, with the appropriate adapters to switch from one size to the other, so that in multi-user system each pipe section can be made with the appropriate diameter to allow for a flow of air capable of meeting the planned simultaneous use requirement.

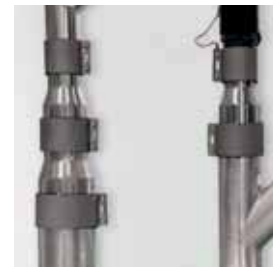

## Criteria for the selection of tubing

The use of metal fittings is necessary in the following cases:

1. suction of easily inflammable or explosive materials, which could explode inside the pipe due to sparks generated by the accumulation of static charges formed by the passage of air through PVC pipes. In order to disperse these charges, an earthing connection must be made to the pipe, which becomes entirely conductive thanks to the special junction sleeves that enable electrical conductivity;
2. suction of incandescent materials, which could puncture the plastic pipes once they have been sucked in;
3. suction of abrasive materials, which could erode the plastic pipework, especially in bends;
4. exposed pipework, where there is a need to prevent environmental dust attracted by the static charges present from being deposited on the external walls of the pipework.

# Industrial system installation

## Zinc coated steel tubes



Article	Description	Pkg	U.m.	Price
● 1850.0F	PVC pipe Ø 50 mm (2 m bars)	1	m	€ 23,50
1863.0F	PVC pipe Ø 60 mm (2 m bars)	1	m	€ 32,00
1880.0F	PVC pipe Ø 80 mm (2 m bars)	1	m	€ 48,00
1810.0F	PVC pipe Ø 100 mm (2 m bars)	1	m	€ 56,00

## Zinc coated 45° elbows



Article	Description	Pkg	U.m.	Price
● 3050.1F	Zinc coated steel elbow 45° Ø 50 mm	1	pc	€ 20,00
3063.1F	Zinc coated steel elbow 45° Ø 60 mm	1	pc	€ 32,00
3080.1F	Zinc coated steel elbow 45° Ø 80 mm	1	pc	€ 55,00
3010.1F	Zinc coated steel elbow 45° Ø 100 mm	1	pc	€ 50,00

## Zinc coated 90° elbows



Article	Description	Pkg	U.m.	Price
● 3050.0F	Zinc coated steel elbow 90° Ø 50 mm	1	pc	€ 21,00
3063.0F	Zinc coated steel elbow 90° Ø 60 mm	1	pc	€ 35,00
3080.0F	Zinc coated steel elbow 90° Ø 80 mm	1	pc	€ 55,00
3010.0F	Zinc coated steel elbow 90° Ø 100 mm	1	pc	€ 70,00

## Zinc coated steel sleeve



Article	Description	Pkg	U.m.	Price
● 1150.1F	Zinc coated steel sleeve Ø 50 mm	5	pcs	€ 21,00
1163.1F	Zinc coated steel sleeve Ø 60 mm	5	pcs	€ 25,50
1180.1F	Zinc coated steel sleeve Ø 80 mm	1	pc	€ 47,00
1110.1F	Zinc coated steel sleeve Ø 100 mm	1	pc	€ 52,00

## Zinc coated steel wye 45°



Article	Description	Pkg	U.m.	Price
● 4050.0F	Zinc coated steel wye 45° Ø 50 mm	1	pc	€ 38,00
4063.0F	Zinc coated steel wye 45° Ø 60 mm	1	pc	€ 50,00
4080.0F	Zinc coated steel wye 45° Ø 80 mm	1	pc	€ 56,00
4010.0F	Zinc coated steel wye 45° Ø 100 mm	1	pc	€ 69,00

## Zinc coated steel extension



Article	Description	Pkg	U.m.	Price
● 6050.0F	Zinc coated steel extension Ø 50/60 mm	1	pc	€ 33,00
8060.0F	Zinc coated steel extension Ø 60/80 mm	1	pc	€ 34,50
1080.0F	Zinc coated steel extension Ø 80/100 mm	1	pc	€ 31,00

## Pipe clamp



Article	Description	Pkg	U.m.	Price
● 1401.50	Pipe clamp Ø 50 mm	10	pcs	€ 4,80
1401.60	Pipe clamp Ø 60 mm	10	pcs	€ 5,30
1401.80	Pipe clamp Ø 80 mm	5	pcs	€ 8,00
1401.100	Pipe clamp Ø 100 mm	5	pcs	€ 10,50

## Antistatic industrial inlet with microswitch



Article	Description	Pkg	U.m.	Price
● 1556.0A	Antistatic industrial inlet with microswitch Ø 32/40	1	pc	€ 128,00
● 1556.0AX	Antistatic industrial inlet with microswitch ATEX Ø 32/40*	1	pc	€ 307,00

\*Inlet with ATEX zone 22 certified microswitch

## Antistatic hose



Article	Description	Pkg	U.m.	Price
● 7037.10AC	Antistatic hose Ø 32 (10 m long)	1	pc	€ 160,00
7037.30A	Antistatic hose Ø 32 (30 m long)	1	pc	€ 456,00
7037.40A	Antistatic hose Ø 40 (30 m long)	1	pc	€ 725,00

## Antistatic inlet connector



Article	Description	Pkg	U.m.	Price
● 7038.0A	Antistatic inlet connector Ø 32	1	pc	€ 65,00
● 7038.1A	Antistatic inlet connector Ø 40	1	pc	€ 45,00

## Antistatic chromium plated handgrip



Article	Description	Pkg	U.m.	Price
● 7039.0A	Antistatic chromium plated handgrip Ø 32	1	pc	€ 85,00

# Sense

## Retractable hose system

Field of application:

domestic

suitable for all central vacuum systems



Wireless (optional)



Sense by Sistem Air is the in-wall hose system that makes **cleaning practical and light**, amplifying the central vacuuming experience to the fullest.

The user can choose to rely on a system that eliminates the clutter of the hose, optimising the installed suction points, and enhancing the design of the room thanks to the high-tech finishes of the covers in **perfect Sistem Air style**.

### FEATURES

- Reduced footprint
- Perfect positioning
- Dedicated space for wiring
- Wireless power on/off
- Versatility of installation
- System sealing



Learn more

# Main features

## The vacuum fits in a drawer

The Sense retractable hose system eliminates hose clutter. This way, the vacuum and all accessories are always ready for use and conveniently stored in small spaces.



## Lightweight

Sense is a system designed to experience the convenience of central vacuuming.

Cleanings are ultra-light and you no longer need to move the hose around the house. It will follow you around.



## Wireless (optional)

When there is a need to switch the system on or off, Flisy 2 allows you to do so with a simple button on the handle.

There is no need to run from room to room to stop the suction.



## Back into the wall

The cleaning hose does not coil up and disappear, it simply goes back into the pipework installed in the wall thanks to the suction force.

The Sense hose always remains ready for cleaning and retracts when it is no longer needed.



# Express your personality

The design, born from the combination of a layer of pure steel and a high-strength plastic mixture, makes the Sense covers a robust furniture accessory, made to be experienced every day.

The cover finishes enhance the ambience in a discreet way, with the tones of brushed steel or demi-matt white. Alternatively, you can liven up the room by choosing to paint it in a colour of your choice thanks to the special .paintable finish.

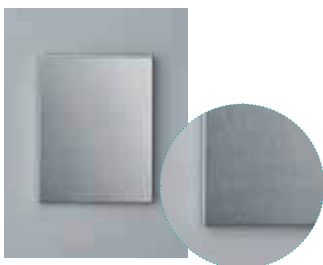

Brushed steel cover

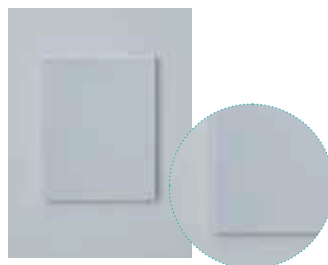

Demi-matt white cover



Paintable finish cover

## Sense retractable hose system installation material

### Installation kit for 1 inlet point Multi Sense



Article	Description	Pkg	U.m.	Price
○ 7230.0	White	1	PCS	€ 349,00

Backplates	Cover	Elbow FF 22,5° - Ø 2"	Elbow FF 45° large - Ø 2"	Elbow FF 90° large - Ø 2"	Glue 60 g	Sleeve PVC Ø 2"	Sleeve Ø 2" → 50 mm	PVC pipe Ø 2"
1 pc Multi Sense	1 pc White	2 pcs	2 pcs	3 pcs	1 pc	7 pcs	1 pc	16 m

### Backplate and Cover



Article	Description	Pkg	U.m.	Price
○ 1450.32	Multi Sense backplates	1	pc	€ 80,00
○ 1450.33	Mono Sense backplates	1	pc	€ 70,00
● 1470.0	Steel Sense Cover	1	pc	€ 65,00
○ 1470.1	White Sense Cover	1	pc	€ 65,00
● 1470.2	Paintable Sense Cover	1	pc	€ 65,00

### Bulk installation material for Sense system by Sistem Air



Article	Description	Pkg	U.m.	Price
○ 1851.0	PVC pipe Ø 2" thick 1,4 mm (bars m 2)	20	m	€ 5,90
○ 3051.6	PVC elbow 22,5° Ø 2" FF	1	pc	€ 6,40
○ 3051.7	PVC elbow 45° Ø 2" FF large	1	pc	€ 13,50
○ 3051.8	PVC elbow 90° Ø 2" FF large	1	pc	€ 19,00
○ 1151.1	PVC sleeve Ø 2"	20	pcs	€ 1,35
○ 5051.1	PVC closing cap Ø 2"	8	pcs	€ 2,60
● 1150.4	PVC sleeve with shutter Ø 2" → 50 mm	1	pc	€ 4,80
○ 4051.2	PVC wye 45°	1	pc	€ 4,90
○ 1401.0	PVC pipe clamp Ø 2"	20	pc	€ 1,80



# Sense system accessories

## Flexible hose



Article	Description	Pkg	U.m.	Price
● 7237.9	Length 9 m	1	pc	€ 143,00
● 7237.12	Length 12 m	1	pc	€ 190,00
● 7237.15	Length 15 m	1	pc	€ 227,00

## Flexible hose with hose cover



Article	Description	Pkg	U.m.	Price
● 7237.9P	Length 9 m	1	pc	€ 297,00
● 7237.12P	Length 12 m	1	pc	€ 366,00
● 7237.15P	Length 15 m	1	pc	€ 504,00

## Sense flexible hose fitting



Article	Description	Pkg	U.m.	Price
● 7038.0S	Plastic Flexible hose - Sense handle fitting	1	pc	€ 13,00

## Sense curved fitting



Article	Description	Pkg	U.m.	Price
● 7039.5	Plastic For Sense retractable hose	1	pc	€ 35,00

## System tech Flisy 2



Article	Description	Pkg	U.m.	Price
○ 7039.4W	Wireless On/off system with remote control receiver	1	pc	€ 233,00

## System Tech Flisy 2 receiver\*



Article	Description	Pkg	U.m.	Price
● 3301.12	Wireless receiver	1	pc	€ 140,00

\*If several receivers are to be installed, just one handle is enough

## Sense cleaning kit Sense



Article	Description	Pkg	U.m.	Price
● 7232.9	Length 9 m	1	pc	€ 357,00
● 7232.12	Length 12 m	1	pc	€ 408,00
● 7232.15	Length 15 m	1	pc	€ 454,00

## Sense cleaning kit with hose cover



Article	Description	Pkg	U.m.	Price
● 7232.9P	Length 9 m	1	pc	€ 500,00
● 7232.12P	Length 12 m	1	pc	€ 557,00
● 7232.15P	Length 15 m	1	pc	€ 690,00

# Cleaning Accessories

Field of application:  
domestic



Accessory connection Ø 32 mm



Sistem Air cleaning accessories respect all surfaces, even the most delicate ones, **guaranteeing a superior degree of hygiene** and a long lifetime.

In particular, the design of the brushes is functional to their ease of use. **Specific shapes with bumper profiles and joints** make it easier to reach the most hidden places.

The **soft, natural bristles** take care of the room, eliminating all dust residue in depth.

A perfect mix, combined with hoses and accessories for every need. **The best, for the best result.**

## FEATURES

- Pure White colour, leaves no traces: protects furniture and materials
- Natural bristles, gentle on surfaces, durable
- No more stress, professional joints accommodate movements

# Main features

The convenience of switching on directly from the handle or the essentiality of the traditional system. Two solutions for managing your central vacuum system.

## On/off wireless Flisy 2



It is immediately recognisable by its pure white colour and the crystal button in the centre of the handle.

Flisy 2 is the wireless on/off system invented by Sistem Air to switch the system on and off at the touch of a button. As often as you like.



## Rechargeable batteries

Flisy 2's rechargeable lithium-ion batteries have an almost infinite lifetime. After many cleaning sessions, it will only need a quick recharge by plugging into a simple USB valve with the supplied cable.

It is recommended not to leave the hose plugged into the valve when not in use to avoid draining the batteries.



## Standard

The **dolphin grey** handle characterises the traditional system for switching the system on and off.

By inserting the hose into the inlet, suction starts. At the end of cleaning operations, simply remove the hose from the inlet valve to switch the system off.



## Natural Trendy brushes

The Natural Trendy line is the quintessence of cleaning tools. Premium quality brushes and accessories for those who do not want to compromise.



# Cleaning accessories

Sistem Air cleaning accessories offer a complete range to meet all cleaning needs. The high build quality and universality with all central vacuum systems make it an exclusive and sought-after product.



**Professional anti-torsion hoses**  
Ultra-resistant and non-deformable.  
Ready for anything



**Ergonomic handles**  
Relieve the weight of the hose  
on the ground



**Protective cover**  
Made of antistatic and washable cotton  
and polyester

## Natural Trendy Brushes

### Floor and carpet brush



Article	Description	Pkg	U.m.	Price
○ 7736.0	width 36 cm Brush with joint and bumper	1	pc	€ 86,00

### Parquet brush



Article	Description	Pkg	U.m.	Price
○ 7735.0	width 30 cm Brush with joint and polishing felt base	1	pc	€ 35,00

### Floor brush



Article	Description	Pkg	U.m.	Price
○ 7747.1	width 30 cm Brush with joint and Natural bristles	1	pc	€ 65,00

### Mattress and tapestry brush



Article	Description	Pkg	U.m.	Price
○ 7744.0	with velvet comb Brush without bristles for regular surfaces	1	pc	€ 19,00

### Clothes brush



Article	Description	Pkg	U.m.	Price
○ 7742.0	extra soft for all fabrics Long natural bristle brush for clothes	1	pc	€ 33,00

### Dusting brush



Article	Description	Pkg	U.m.	Price
○ 7743.0	ideal for cleaning furniture Triangular brush with natural bristles	1	pc	€ 18,00

### Radiator brush



Article	Description	Pkg	U.m.	Price
○ 7746.0	perfect for radiators and decorative radiators To be used in combination of Art. 7745.0	1	pc	€ 16,00

### Corner nozzle



Article	Description	Pkg	U.m.	Price
○ 7745.0	extra long 35 cm Fine nozzle for suction in difficult places	1	pc	€ 12,70

# Standard brushes

## Open Space Brush



Article	Description	Pkg	U.m.	Price
● 7047.0	width 37 cm Open Space Brush	1	pc	€ 72,00

## Turbo carpet beater brush



Article	Description	Pkg	U.m.	Price
● 7034.0	width 28 cm With Turbo Technology. No batteries required	1	pc	€ 159,00

## 180° brush



Article	Description	Pkg	U.m.	Price
● 7047.9	width 30 cm With 180° joint	1	pc	€ 64,00

## Pet brush



Article	Description	Pkg	U.m.	Price
● 7049.0	for mantle cleaning Bridle type with soft synthetic bristles	1	pc	€ 85,00

## Brush for liquids



Article	Description	Pkg	U.m.	Price
● 7033.1	width 30 cm With rubber bristles	1	pc	€ 49,00

## Brush for pipes and beams



Article	Description	Pkg	U.m.	Price
● 7033.2	Ideal for dusting pipes and beams Elbow with bristles	1	pc	€ 113,00

## Tapestry turbo brush



Article	Description	Pkg	U.m.	Price
● 7033.3	width 16 cm With Turbo Technology. No batteries required	1	pc	€ 99,00

## Cleaning accessories

### Flexible pipes

#### Wireless on/off Flisy 2 flexible pipes



Article	Description	Pkg	U.m.	Price
● 7037.7W	7 m pipe	1	pc	€ 255,00
7037.9W	9 m pipe	1	pc	€ 270,00

Wireless switching hose

#### Flexible pipe



Article	Description	Pkg	U.m.	Price
● 7037.7	7 m pipe	1	pc	€ 70,00
7037.9	9 m pipe	1	pc	€ 89,00
7037.18	18 m pipe	1	pc	€ 186,00

Hose without fittings

#### Mélange hose cover



Article	Description	Pkg	U.m.	Price
● 7037.1	7 m pipe	1	pc	€ 78,00
7037.4	9 m pipe	1	pc	€ 100,00

Hose cover for flexible hose

### Extensions

#### Rigid extension



Article	Description	Pkg	U.m.	Price
● 7040.0	Chrome-plated	1	pc	€ 42,50

Standard cleaning tube

#### Telescopic extension



Article	Description	Pkg	U.m.	Price
● 7040.1	Chrome-plated	1	pc	€ 64,00

Length-adjustable tube

#### Basic extension



Article	Description	Pkg	U.m.	Price
● 7040.2	Plastic	1	pc	€ 25,50

Basic cleaning tube

## Handgrip

### Curved fitting



Article	Description	Pkg	U.m.	Price
● 7039.0	Chrome-plated With pressure regulator	1	pc	€ 37,00

### Ergonomic curved fitting



Article	Description	Pkg	U.m.	Price
● 7039.1	Plastic With pressure regulator	1	pc	€ 26,50

### Flisy 2 on/off fitting



Article	Description	Pkg	U.m.	Price
○ 7039.10W	Wireless on/off wireless system	1	pc	€ 207,00

### System Tech Flisy 2



Article	Description	Pkg	U.m.	Price
○ 7039.4W	Wireless on/off system with wireless receiver	1	pc	€ 233,00

### System Tech Flisy 2\* receiver



Article	Description	Pkg	U.m.	Price
● 3301.12	Wireless receiver	1	pc	€ 140,00

\*If several receivers are to be installed, only one handle can also be used.

## Fittings

### Fitting pipe/inlet



Article	Description	Pkg	U.m.	Price
● 7038.0M	With metal ring For standard switching	1	pc	€ 15,00

### Extension for flexible hose



Article	Description	Pkg	U.m.	Price
● 7048.0	Rubber To connect two flexible hoses	1	pc	€ 12,50

### Security object holder



Article	Description	Pkg	U.m.	Price
● 7040.5	Plastic Prevents accidental suction	1	pc	€ 35,00

## Accessories holder

### Mini accessories holder



Article	Description	Pkg	U.m.	Price
● 7041.1	To be hung on the wall For flexible hose and 4 accessories	1	pc	€ 35,00

### Maxi accessories holder



Article	Description	Pkg	U.m.	Price
● art. 7041.0	To be hung on the wall For flexible hose and 10 accessories	1	pc	€ 64,00

### Accessories trolley



Article	Description	Pkg	U.m.	Price
● art. 7041.2	With weels For flexible hose and accessories	1	pc	€ 430,00

## Special cleaning kit

### Oven accessory kit

Accessory kit for oven cleaning, with insulated handle to protect against heat. This allows use even when the plates are still hot. Modular, extendable handle for cleaning industrial ovens up to 3 m deep.

Earthing can be connected with the included accessory for suction of materials generating electrostatic charge or at risk of explosion such as flour.



Article	Description	Pkg	U.m.	Price
○ 7032.3	Steel Ø 32 Allows suction of the oven while still hot	1	pc	€ 670,00



# Brushes and accessories Ø 40

## Pipes and fittings

### Flexible pipe



Article	Description	Pkg	U.m.	Price
● 7037.2	Ø 40 mm length 10 m	1	pc	€ 175,00

### Fitting flexible pipe/handgrip



Article	Description	Pkg	U.m.	Price
● 7038.1	Fitting flexible pipe/handgrip Ø 40	1	pc	€ 18,00

### Swivel fitting



Article	Description	Pkg	U.m.	Price
● 7038.2	Swivel fitting pipe/inlet Ø 40	1	pc	€ 24,50

## Chrome plated tubes

### Pair of chrome-plated pipes



Article	Description	Pkg	U.m.	Price
● 7039.20	Extension Ø 40	1	pc	€ 62,00

## Brushes

### Floor brush



Article	Description	Pkg	U.m.	Price
● 7047.2	Width 48 cm	1	pc	€ 60,00

### Dusting brush



Article	Description	Pkg	U.m.	Price
● 7047.3	Round brush	1	pc	€19,50

### Corner nozzle



Article	Description	Pkg	U.m.	Price
● 7047.4	Flat top	1	pc	€ 16,00

### Liquid brush



Article	Description	Pkg	U.m.	Price
● 7033.8	With rubber bristles	1	pc	€ 96,00

# On/off Flisy 2 cleaning kit



## Flisy 2 basic cleaning kit



Article	Description	Pkg	U.m.	Price
<input type="radio"/> 7530.7W	Cleaning kit with 7 m wireless on/off hose	1	pc	€ 313,00
<input type="radio"/> 7530.9W	Cleaning kit with 9 m wireless on/off hose	1	pc	€ 324,00

## Flisy 2 Smart cleaning kit













Article	Description	Pkg	U.m.	Price
<input type="radio"/> 7532.7W	Cleaning kit with 7 m wireless on/off hose	1	pc	€ 410,00
<input type="radio"/> 7532.9W	Cleaning kit with 9 m wireless on/off hose	1	pc	€ 426,00

## Flisy 2 Deluxe cleaning kit



Article	Description	Pkg	U.m.	Price
<input type="radio"/> 7531.9W	Cleaning kit with 9 m wireless on/off hose	1	pc	€ 525,00

	BASIC	SMART	DELUXE
<b>7530.7W</b> 7 m pipe		<b>7532.7W</b> 7 m pipe	-
<b>7530.9W</b> 9 m pipe		<b>7532.9W</b> 9 m pipe	<b>7531.9W</b> 9 m pipe

	Flisy 2 7/9 m on/off hose	✓	✓	✓
	Mini accessories holder for 4 pcs	✓	-	-
	Maxi accessories holder for 10 pcs	-	✓	✓
	Dusting brush with natural bristles	✓	✓	✓
	Corner nozzle	✓	✓	✓
	Chrome-plated rigid extension	✓	✓	-
	Floor brush Natural	✓	-	✓
	Floor and Carpet Brush Natural	-	✓	✓
	Clothes brush with bristles Natural	-	✓	✓
	Mattress & tapestry brush Natural	-	✓	✓
	Security object holder	-	✓	-
	Chrome-plated telescopic extension	-	-	✓
	Radiator brush Natural	-	-	✓
	Mélange hose cover	-	-	✓

# Standard cleaning kit



STANDARD

## Basic cleaning kit



Article	Description	Pkg	U.m.	Price
<input type="radio"/> 7530.7	Cleaning kit with standard 7 m hose	1	pc	€ 147,00
<input type="radio"/> 7530.9	Cleaning kit with standard 9 m hose	1	pc	€ 156,00

## Smart cleaning kit



Article	Description	Pkg	U.m.	Price
<input type="radio"/> 7532.7	Cleaning kit with standard 7 m hose	1	pc	€ 280,00
<input type="radio"/> 7532.9	Cleaning kit with standard 9 m hose	1	pc	€ 273,00

## Deluxe cleaning kit



Article	Description	Pkg	U.m.	Price
<input type="radio"/> 7531.9	Cleaning kit with standard 9 m hose	1	pc	€ 400,00

		BASIC	SMART	DELUXE
		<b>7530.7</b> 7 m pipe	<b>7532.7</b> 7 m pipe	-
		<b>7530.9</b> 9 m pipe	<b>7532.9</b> 9 m pipe	<b>7531.9</b> 9 m pipe
	Flexible hose with standard fittings 7/9 m	✓	✓	✓*
	Mini accessories holder for 4 pcs	✓	-	-
	Maxi accessories holder for 10 pcs	-	✓	✓
	Dusting brush with natural bristles	✓	✓	✓
	Corner nozzle	✓	✓	✓
	Chrome-plated rigid extension	✓	✓	-
	Floor brush Natural	✓	-	✓
	Floor and Carpet Brush Natural	-	✓	✓
	Floor and Carpet Brush Natural	-	✓	✓
	Mattress & tapestry brush Natural	-	✓	✓
	Security object holder	-	✓	-
	Chrome-plated telescopic extension	-	-	✓
	Radiator brush Natural	-	-	✓
	Mélange hose cover	-	-	✓

## Special separator

To preserve the efficiency of the system, special separators must be used if it is necessary to suck in liquids or cold ash. They are used as required and connect directly to the plant's suction inlets.

### Liquid separator with brush

It is equipped with a special floating mechanism that stops liquids and dust when the level is reached, leaving the hose and the central vacuum cleaner dry.

It allows suction of up to 20 l of liquids. It is supplied with a brush with rubber bristles and a hose to be inserted into the suction inlets. To vacuum liquids, connect the Ø 32 mm hose in use for normal cleaning operations to the separator.



Article	Description	Pkg	U.m.	Price
● 7033.0	Polypropylene Complete with brush with rubber bristles Hose to connect to the system	1	pc	€ 300,00

### Ashes separator

Ashes represent a danger to the motor of the central vacuum cleaner, which is why it is necessary to use the special stainless steel separator equipped with a special REI 60 filter (see spare parts section page 133) for cleaning stoves, chimneys and boilers. The ash sucked in must be cold.

The capacity of the separator is 36 l and it is supplied complete with hose to be inserted into the suction inlets. To vacuum the ash, connect the Ø 32 mm hose in use for normal cleaning operations to the separator.



Article	Description	Pkg	U.m.	Price
● 7033.7	Stainless steel Hose to connect to the system	1	pc	€ 307,00

Express  
yourself  
in cleaning



## Filter cartridges

Filter replacement  
recommended every 2 years

## Aluminium fibre filter



Article	Description	Pkg	U.m.	Price
● 1610.0R	Conical polyester and aluminium filter <i>For central vacuum cleaners</i> Tecno Prime Tecno R-Evolution	1	pc	€ 100,00

## Standard filter



Article	Description	Pkg	U.m.	Price
● 1610.0	Polyester filter <i>For central vacuum cleaners</i> Tecno Evox Tecno Style Tecno Activa Tecno Evolution Linea Color SA5	1	pc	€ 81,00

## White line filter



Article	Description	Pkg	U.m.	Price
● 1610.1	Polyester filter <i>For central vacuum cleaners</i> SA200 SA300 SA400	1	pc	€ 93,00

## Separator line filters



Article	Description	Pkg	U.m.	Price
● 1610.2	Polyester filter <i>For central vacuum cleaners</i> LT80 Tecno Block Max	1	pc	€ 160,00



Article	Description	Pkg	U.m.	Price
● 1610.4	Polyester filter <i>For central vacuum cleaners</i> LT160	1	pc	€ 325,00

## Mini line Filter



Article	Description	Pkg	U.m.	Price
● 1610.5	Polyester filter <i>For central vacuum cleaners</i> Tecno Style Mini Tecno Activa Mini Tecno Evolution Mini Silent Mini	1	pc	€ 64,00

### SA7 Filter



Article	Description	Pkg	U.m.	Price
● 1610.6	Polyester filter <i>For central vacuum cleaners</i> SA7	1	pc	€ 69,00

### Tecno Star filter



Article	Description	Pkg	U.m.	Price
● 1610.7	Polyester filter <i>For central vacuum cleaners</i> Tecno Star Dual Power      Revo Block 500 Tecno Star                              Revo Job	1	pc	€127,00

### Revo Block filter



Article	Description	Pkg	U.m.	Price
● 1610.7R	Polyester filter <i>For central vacuum cleaners</i> Revo Block 700                      Revo Block 1200 Revo Block 700 Plus              Revo Block 1500 Revo Block 1000                    Revo Block 1800	1	pc	€ 186,00

### Compact line filter



Article	Description	Pkg	U.m.	Price
● 1610.9	Polyester filter <i>For central vacuum cleaners</i> Wolly 2                              T-Box Wolly                                    T-Smart	1	pc	€48,00

### Micro filter



Article	Description	Pkg	U.m.	Price
● 1610.15	Sponge filter <i>For central vacuum cleaners</i> Sistem Cube	1	pc	€ 38,00



Article	Description	Pkg	U.m.	Price
● 1610.16	Sponge filter <i>For central vacuum cleaners</i> Sistem Test	1	pc	€ 41,00

### Fireproof cloth filter



Article	Description	Pkg	U.m.	Price
● 1610.10	Fireproof cloth filter <i>For central vacuum cleaners</i> Ashes separator	1	pc	€ 72,00

## Bags

## 36 litre bags



Article	Description	Pkg	U.m.	Price
● 1614.0	Plastic bag (pack of 20) <i>For central vacuum cleaners</i> SA 200 SA 300 SA 400	1	pc	€ 60,00

## 20 litre bags



Article	Description	Pkg	U.m.	Price
● 1614.1	Plastic bag (pack of 20) <i>For central vacuum cleaners</i> Color line White line	1	pc	€ 21,00

## Tecno Star bags



Article	Description	Pkg	U.m.	Price
● 1614.2	Plastic bag (pack of 20) <i>For central vacuum cleaners e separatori polveri</i> Tecno Star                      Tecno Block Tecno Star Dual Power      LT50 Revo Block 500                LT80	1	pc	€ 70,00

## Separator bags



Article	Description	Pkg	U.m.	Price
● 1614.3	Plastic bag (pack of 20) <i>For central vacuum cleaners e separatori polveri</i> Revo Block 700/700 Plus      Revo Block 1800 Revo Block 1000                LT 160 Revo Block 1200                Industrial Clean Big Revo Block 1500	1	pc	€ 90,00

## Bags with tensioners



Article	Description	Pkg	U.m.	Price
● 1614.4	Plastic bag (pack of 10) <i>For central vacuum cleaners</i> Universal* <small>*except Wolly, Tecno Star, T-Box, Sistem Cube and the separators</small>	1	pc	€ 51,00

## Bi-Vac bags



Article	Description	Pkg	U.m.	Price
● 1614.5	Microfibre bag (pack of 5) <i>For central vacuum cleaners</i> Tecno Prime Tecno R-evolution T-Smart	1	pc	€ 47,00



### Cube bags



Article	Description	Pkg	U.m.	Price
● 1614.15	Paper bags (pack of 10) <i>For central vacuum cleaners</i> Sistem Cube	1	pc	€ 42,00

### Wolly bags



Article	Description	Pkg	U.m.	Price
○ 8220.0	Microfibre bags (pack of 10) <i>For central vacuum cleaners</i> Wolly 2 Wolly	1	pc	€ 51,00

### T-Box bags



Article	Description	Pkg	U.m.	Price
○ 8220.1	Microfibre bags (pack of 10) <i>For central vacuum cleaners</i> T-Box	1	pc	€ 51,00

### Jolly bags



Article	Description	Pkg	U.m.	Price
○ 8402.0	Paper bags (pack of 5) <i>For central vacuum cleaners</i> Jolly People Jolly Contact	1	pc	€ 18,00

## FREQUENT QUESTIONS

### What is special about a central vacuum system compared to household appliances?

The central vacuum cleaner expels the vacuumed pollutants outside without letting them flow back in. Give a try: put your hand behind an appliance to feel the warm breath of the drain. That air is full of micro-dust that goes right back to where you just cleaned, but also were you breathe and live your most precious moments.

### Some advertisements for vacuum appliances say that the filter blocks over 99% of pollutants. Can I be sure of this?

Absolutely not, these are fake news. The filter is not a plug, and to perform its function it has to let air pass through. If it retained all the dust, it would not even vacuum up a crumb.

### Should I put an inlet valve in every room?

No, a single inlet valve cleans approximately 35 m<sup>2</sup> of surface area. Simply place them in strategic spots for optimal coverage.

### Why should I choose it over a vacuum cleaner or robot?

It is the only system in the world that expels allergens and mites out of rooms. It is powerful, energy-saving, very low maintenance and, once done, lasts forever.

### Is it only suitable for luxury or large houses? Is it very expensive?

That's nonsense! Even the smallest studio apartment is entitled to a healthy level of cleanliness. Prices vary depending on the square footage of the property, but are comparable to a high-end appliance.

### Can it get clogged?

No, what passes through the small hose slides out into the big one. The cleaning hose is 3 cm in diameter while the underfloor hose is a good 5 cm!

### I have touchy neighbours and I don't want to cause trouble: do they risk finding their balcony full of dust?

No, only filtered air comes out of the external vent. Micro-dust, invisible to the naked eye, disperses into the atmosphere without creating a nuisance.

### Where does the dirt go?

In the dust container of the central vacuum cleaner, which has to be emptied approximately twice a year.

### Will I have to clean the pipes?

You will never have to worry about cleaning the pipes because the vacuumed air creates a cyclone that keeps the dirt in the centre, avoiding residue.

## GENERAL TERMS AND CONDITIONS OF SALE

### DELIVERY

The delivery terms, specified in the order confirmation, are to be considered indicative and in any case shall be understood as relating to the delivery of the goods to the forwarding agent, who will forward them to their destination. Claims for damages resulting from delays in the delivery of goods shall not be accepted.

### RETENTION OF TITLE

The goods are sold under a Retention of Title Agreement in accordance with Articles 1523 et seq. of the Civil Code; therefore, until the full payment of the price, they shall remain the property of Tecnoplus s.r.l.

### PAYMENTS

Payments shall be made in the manner and on the terms stated in the invoice: in the event of delay, interest shall be charged at the official discount rate plus 3 points, commencing on the day following the day agreed for payment. Any objections to the goods shall not exempt the customer from making payment within the agreed terms. Tecnoplus s.r.l. invoices shall be deemed accepted if not contested by letter with return receipt within 8 days of receipt.

### TRANSPORT

The goods travel at the total risk and peril of the purchaser, even if sent carriage paid. Therefore, in the event of delays, shortages, damage, theft, etc., complaints must be addressed to the carrier alone and solely responsible. Transport charges are applied according to the terms of the order.

### QUANTITATIVES

Quantities may be decreased or increased without notice depending on availability and in compliance with the original packaging or wrapping. A surcharge of 3% on the price will be charged on all articles in quantities less than the standard packaging as a fee for non-standard handling. Items in this price list may be changed or removed from sale at the company's discretion.

### RETURNS

Returns of goods without prior written authorisation from Tecnoplus s.r.l. are not accepted. Unauthorised returns of goods and charging of non-agreed transport costs will be sent back to the sender.

### COMPETENT COURT

The Court of Pavia shall have jurisdiction over any disputes.

List prices are VAT excluded. Tecnoplus S.r.l reserves the right to make technical, chromatic or aesthetic changes to the products mentioned in this document at any time. All images are included for illustrative purposes and are the property of Tecnoplus S.r.l., their use is subject to approval. By its nature, the printed edition may not be up to date.

**We recommend that you consult the latest revision at [sistemair.it/download](http://sistemair.it/download)**



For conventional warranty conditions, please refer to [sistemair.com](http://sistemair.com)



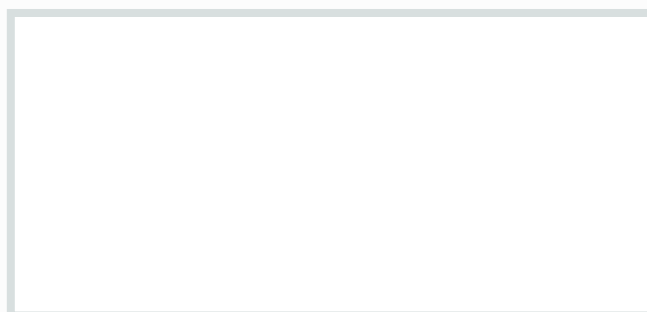

**Sistem Air**  
since 1993 Group

27020 Gravellona Lomellina (PV) ITALIA - Via Cilavegna, 53  
Tel. + 39 0381 650082 - WhatsApp +39 340 4090146 - info@sistemair.com